

# CON770 Series Installation Instructions

(Medium Duty, Concealed Mount - MULTI-FUNCTION)

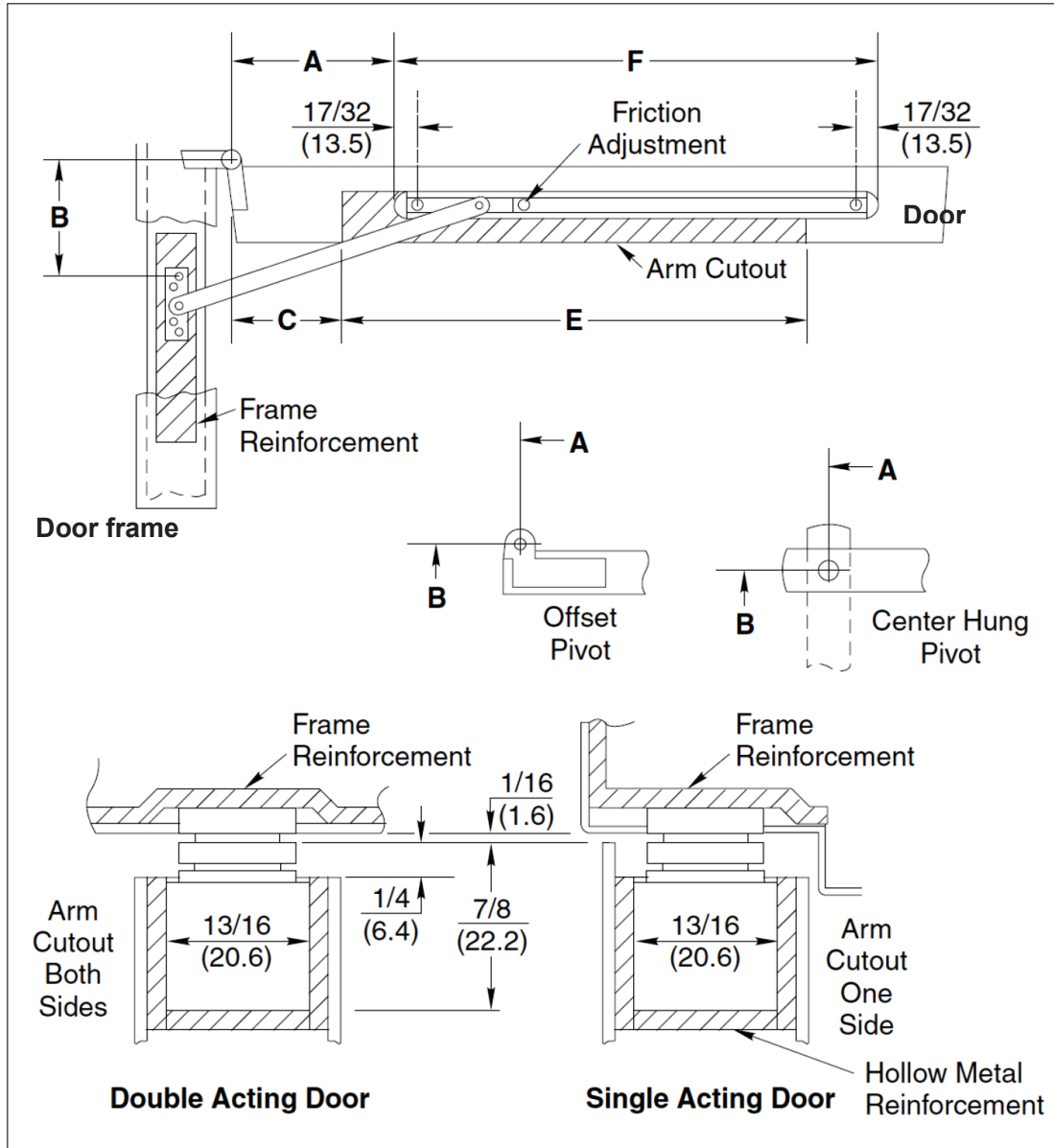

### Installation:

1. Select proper dimensions from the dimension chart.
2. Locate "B" dimension on frame and mortise 3/16" deep for jamb bracket.
3. Locate "A" and "F" dimensions on center line of door and mortise 13/16" wide x 7/8" deep for channel. 1/16" head clearance shown. Coordinate the arm and rail cutout dimensions if head clearance varies.
4. Locate "C" and "E" dimensions on top of door and mortise 1/4" deep as shown for arm clearance.
5. Install door stop with screws provided.

### Notes:

1. All hollow metal frames are to be provided with 3/16" min. thickness x 12" min. length reinforcement plates.
2. All hollow metal doors are to be properly reinforced as shown.
3. If dead stop is required add 5/8" to "A" dimension.
4. A, B and C dimensions are measured from center line of pivot, not edge of door.
5. Reversible, non-handed.
6. All dimensions are given in inches.

# CON770 Series Installation Instructions

(Medium Duty, Concealed Mount - MULTI-FUNCTION)

CON770 Series Dimensions							
Hinge	Model	Door opening	A	B	C	E	F
$1\frac{3}{4}$ ~ $2\frac{1}{4}$ Butts & $\frac{3}{4}$ Offset Pivot	CON772H	18~24	$1\frac{3}{16}$	$3\frac{11}{16}$	0	$15\frac{5}{16}$	$15\frac{7}{8}$
	CON773H	$24\frac{1}{16}$ ~30	4	$4\frac{3}{8}$	$2\frac{9}{16}$	$16\frac{9}{16}$	$17\frac{1}{16}$
	CON774H	$30\frac{1}{16}$ ~36	$6\frac{3}{4}$	$5\frac{9}{16}$	$4\frac{11}{16}$	19	$18\frac{13}{16}$
	CON775H	$36\frac{1}{16}$ ~42	$9\frac{7}{8}$	$7\frac{1}{4}$	$6\frac{3}{8}$	23	$21\frac{1}{4}$
	CON776H	$42\frac{1}{16}$ ~48	$13\frac{13}{16}$	$8\frac{1}{2}$	$7\frac{5}{8}$	$27\frac{1}{2}$	$23\frac{1}{16}$
Center Hung	CON772H	---	---	---	---	---	---
	CON773H	27~32	$5\frac{7}{16}$	$6\frac{1}{8}$	$5\frac{1}{4}$	$15\frac{5}{8}$	$17\frac{1}{16}$
	CON774H	$32\frac{1}{16}$ ~ $38\frac{1}{2}$	$7\frac{3}{16}$	6	$5\frac{9}{32}$	19	$18\frac{13}{16}$
	CON775H	$38\frac{9}{16}$ ~45	$10\frac{5}{16}$	$7\frac{11}{16}$	$6\frac{13}{16}$	23	$21\frac{1}{4}$
	CON776H	$45\frac{1}{16}$ ~48	$14\frac{1}{4}$	$8\frac{15}{16}$	$8\frac{1}{16}$	$27\frac{1}{2}$	$23\frac{1}{16}$

### Adjust the degree of stop:

1. Use a 3/16 hexagon key wrench, loosen the set screw in the shock block.
2. Open door to desired degree of opening.
3. Slide shock block and spring until the spring touches slider cam.
4. Tighten set screw.
5. Verify door opening position and re-adjust as needed.

