

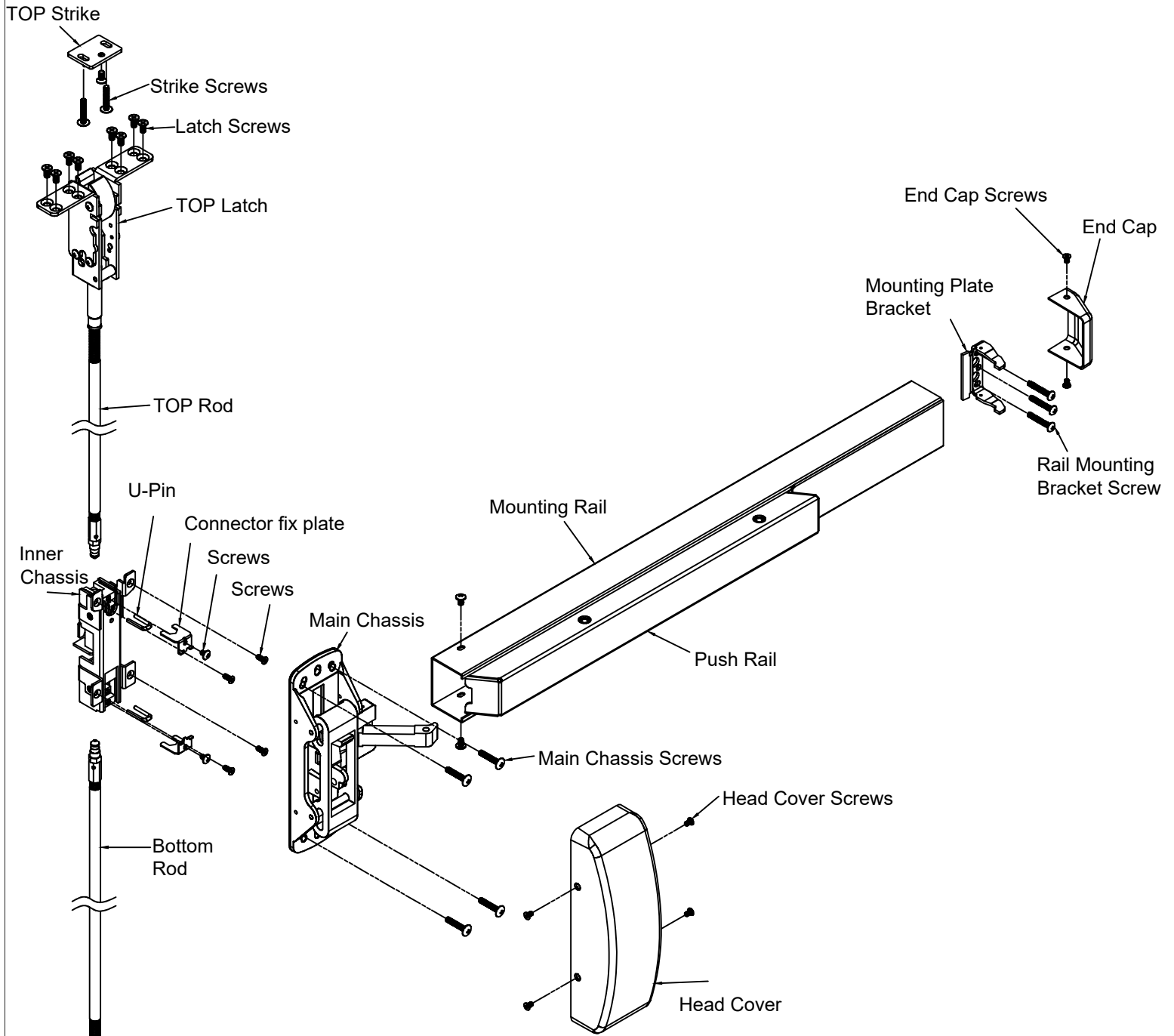

INSTALLATION INSTRUCTION

N-F98CVR CONCEALED VERTICAL ROD EXIT DEVICE



TO CHANGE BOTTOM LATCH FOR BOTTOM STRIKE

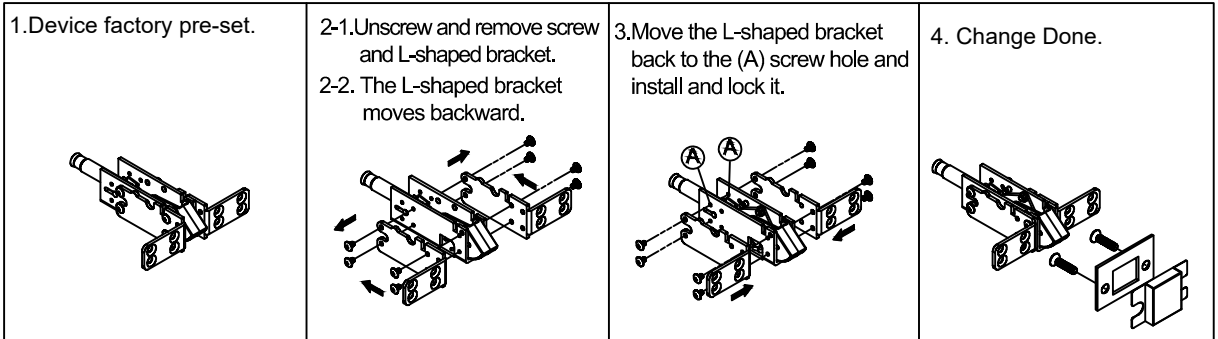

1.INSTALL INNER CHASSIS & TOP LATCH

1

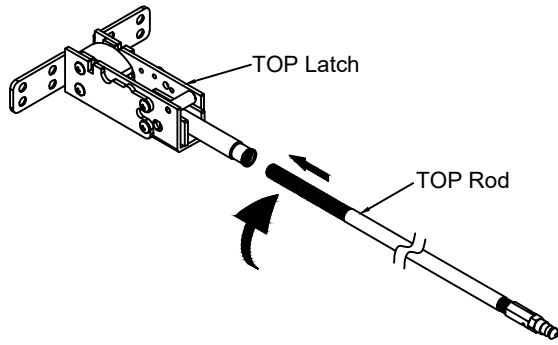

2

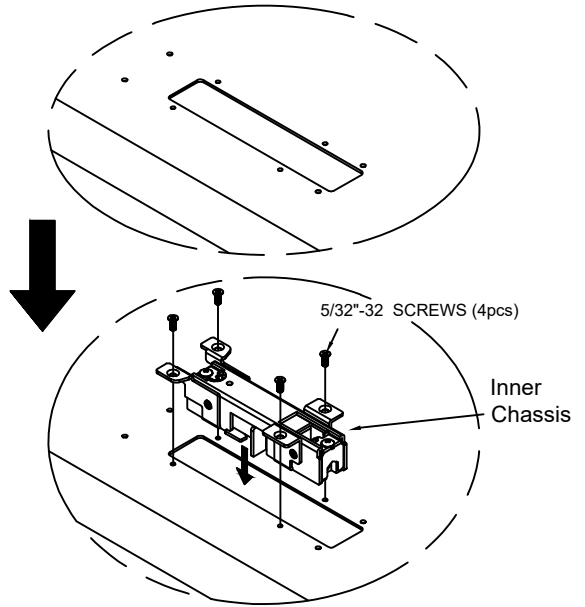

3

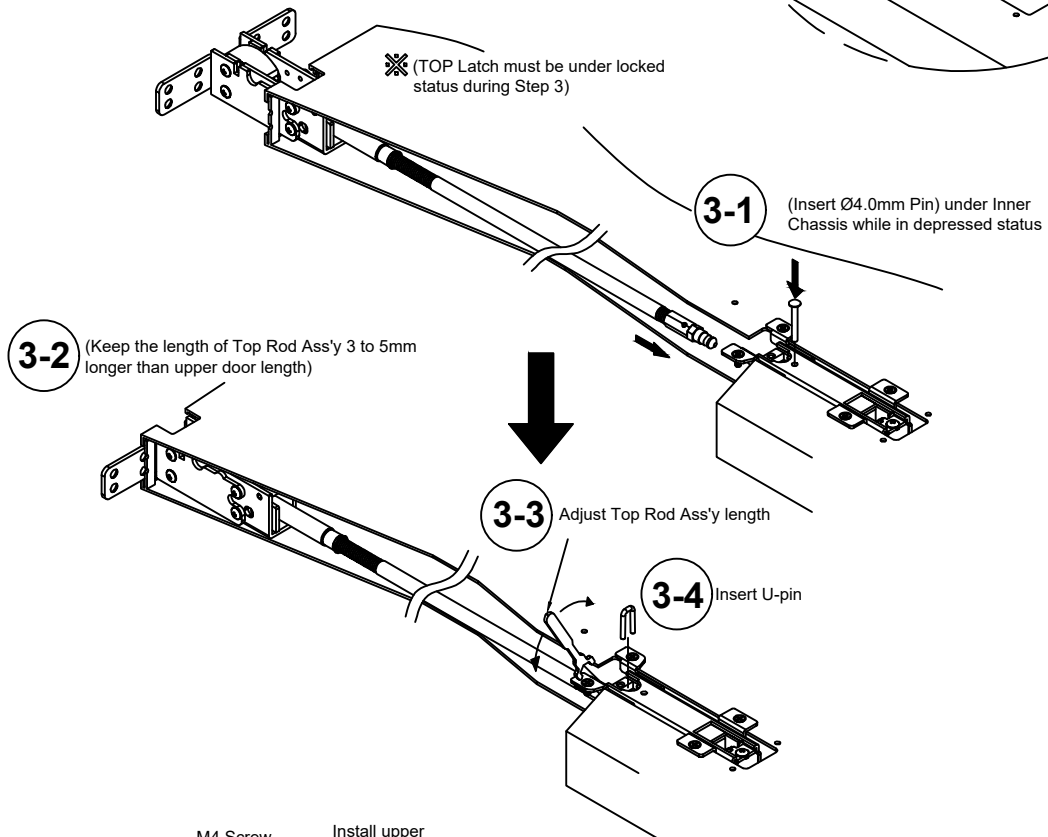

4

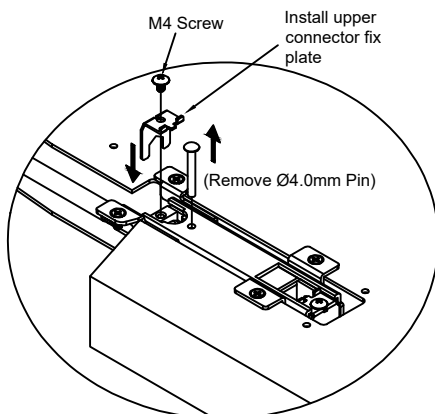

5 Install latch screws

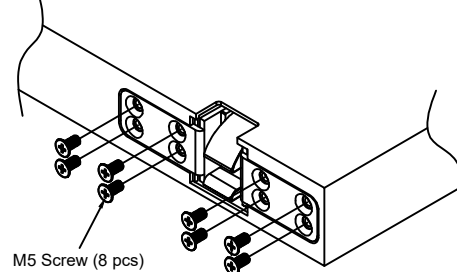

2.INSTALL BOTTOM LATCH (Skip this step if less Bottom Rod)

1 Attached Rod to Bottom latch

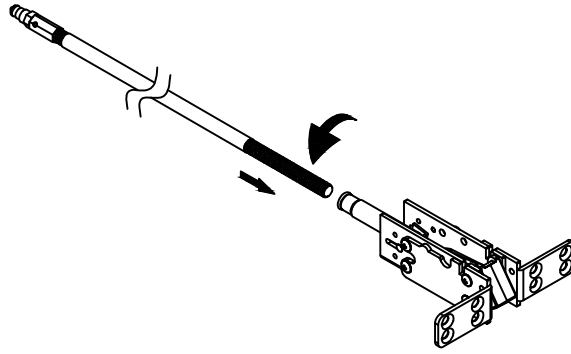

2

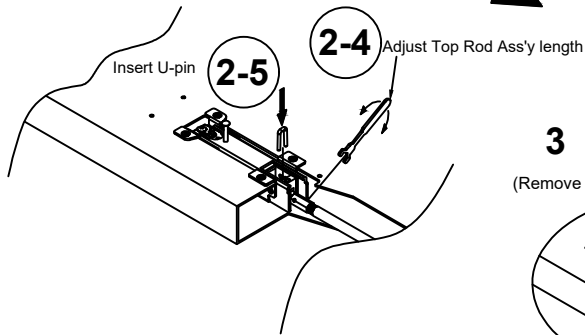
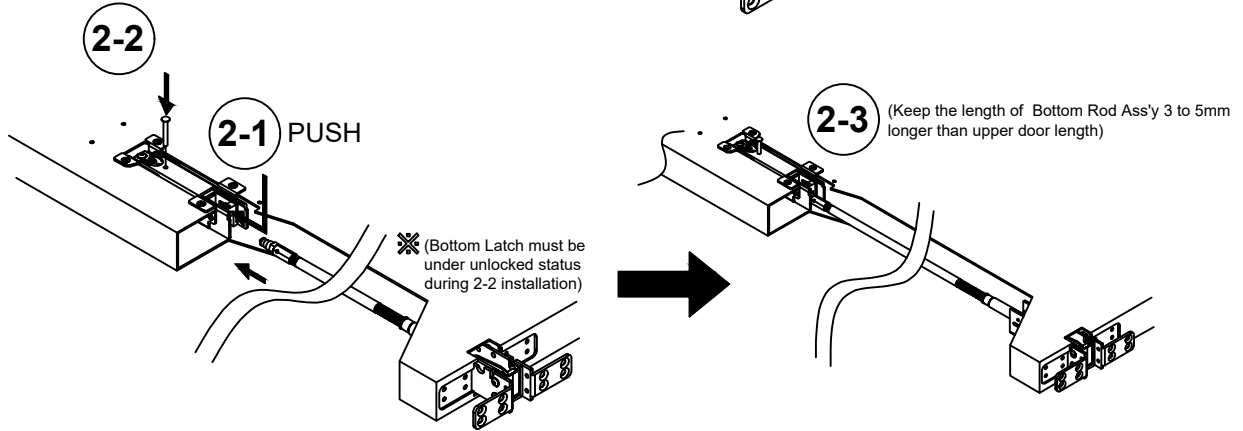

3

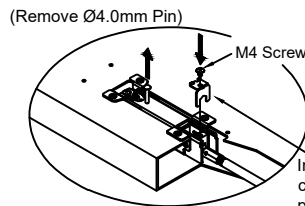

4 Install latch screws

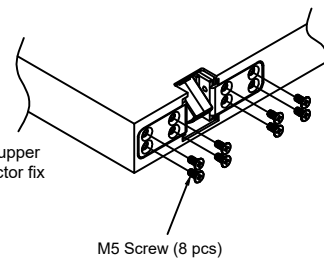

3.INSTALL TOP & BOTTOM STRIKE (Please Follow TEMPLATE)

1 TOP Strike

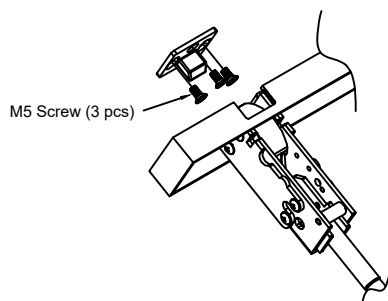

2 Bottom Strike

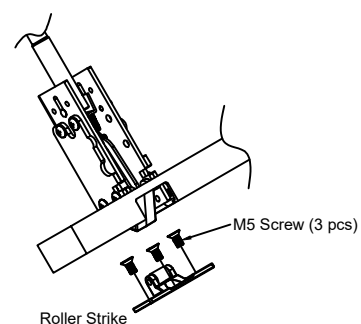

TO CHANGE HAND OF N-F98CVR EXIT DEVICE

1. LHR

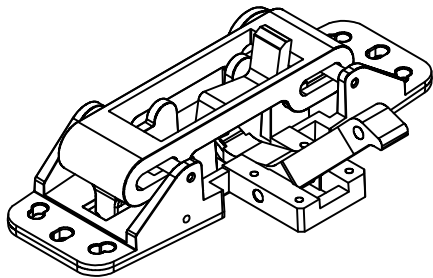

- 2-1. Remove chassis pin & main slide & tube.
- 2-2. Remove lift lever & lift lever pin.
- 2-3. Rotate 180° main slide & lift lever

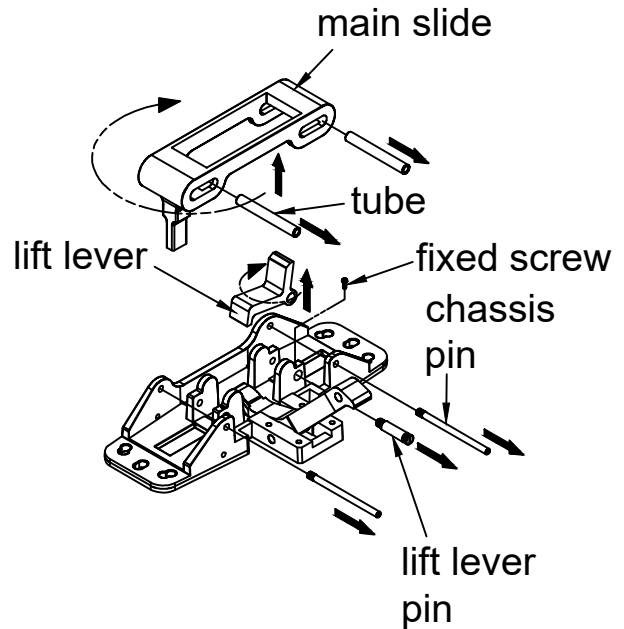

- 3-1. Reassemble lift lever at opposite side, as shown.
- 3-2. Replace main slide and chassis pin and lift lever pin and fixed screw.

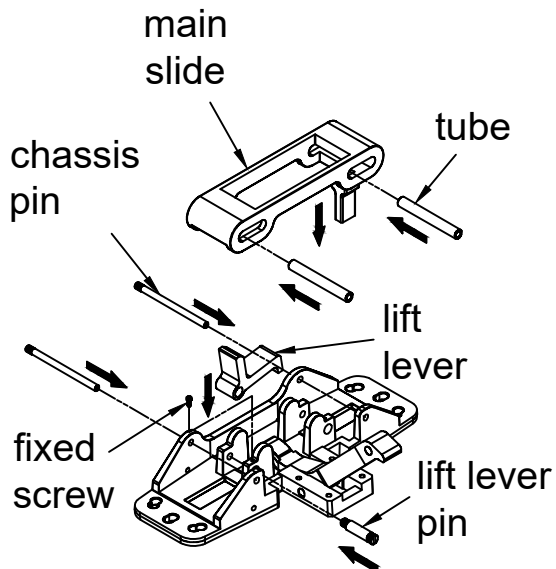

1. RHR Done.

