

INSTRUCTIONS FOR INSTALLING HEAVY DUTY LEVER LOCK

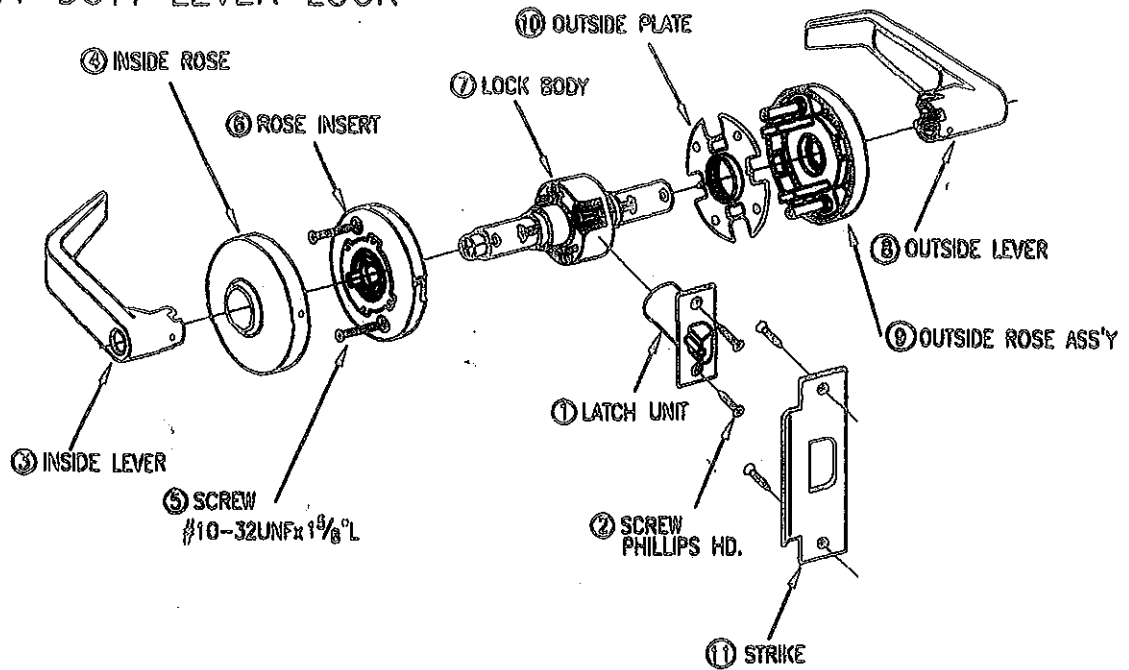

TOOLS REQUIRED
PUSH PIN (PROVIDED)
NO. 2 PHILLIPS SCREWDRIVER
1/8-INCH DRILL BIT
5/16"-INCH DRILL BIT

THIS LOCK IS FACTORY-PACKED FOR 1 3/8" THICK DOORS.

1. MARK DOOR

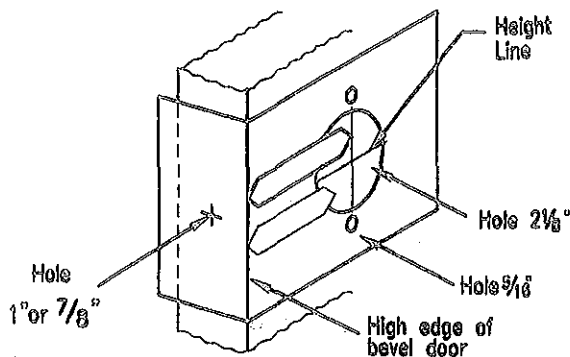

Mark height line on edge and face of door. Detach stub of template and mark center of door thickness on heightline. Fold template at proper marking for bevel of door (high or low bevel or flat). Position center line of template on height line. Hold in place and mark center point for 2 1/8" hole. And then the 1" or 7/8" hole. Also mark for 5/16" holes for mounting screws.

2. BORE HOLES

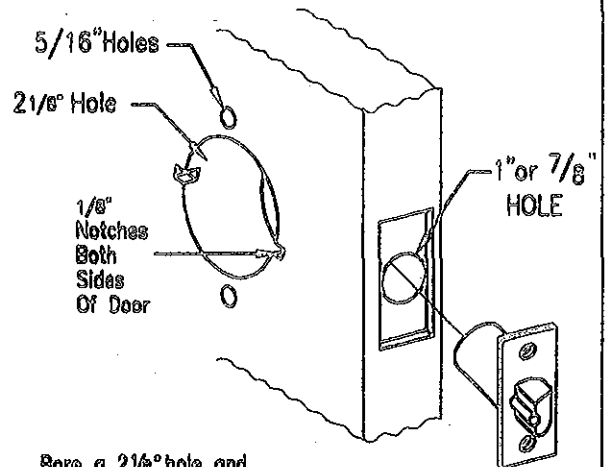

Bore a 2 1/8" hole and 5/16" holes. Bore holes from both sides of door to avoid splintering wood.

NOTE: We recommend using a drill guide to ensure straight holes. Bore a 1" or 7/8" hole straight into door edge to intersect with center of 2 1/8" hole. Use latch front faceplate to pattern for cutout. Front should fit flush with door edge. Install latch with screws provided.

(Wood door applications)

For proper alignment of lock chassis and lever, cut out notches for anchor plate lugs from both sides of door on horizontal height line. Mortise for anchor plates on both sides of door (see template).

NOTE: Width of notches should not exceed 1/8" for snug fit of anchors.

3. DISASSEMBLE INSIDE TRIM

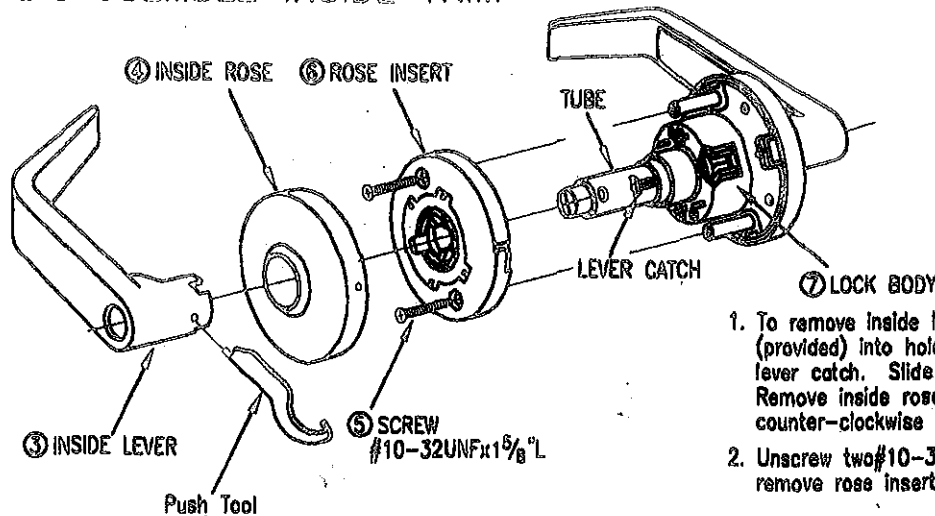

1. To remove inside lever (3). Insert push tool (provided) into hole on lever to depress the lever catch. Slide the lever from the tube. Remove inside rose (4) by slightly twisting counter-clockwise and pulling off.
2. Unscrew two #10-32UNFx $1\frac{5}{8}$ " L (5) screw and remove rose insert (6).

4. INSTALL OUTSIDE UNIT

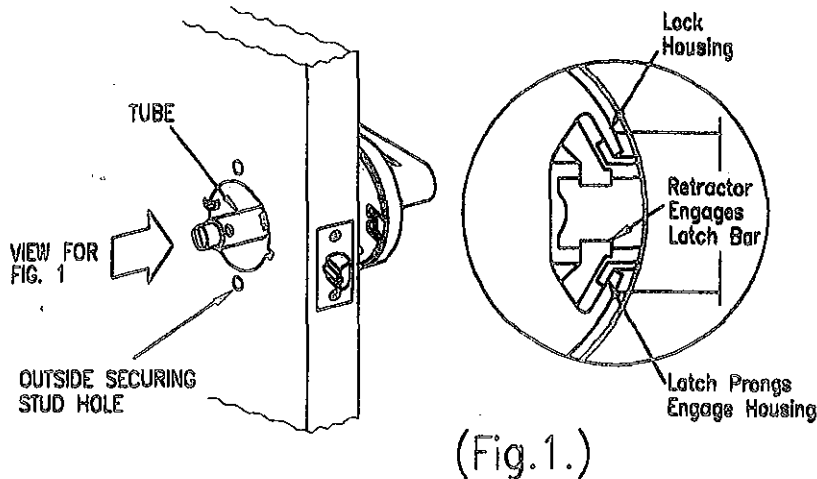

The lock body must engage the latch unit prongs as shown. The lock body retractor must engage the latch unit tail piece. Door must be open when installing lockset with guarded latch unit.

NOTE :

1. Be sure latch unit tail piece is centered about lock body retractor. Adjust it if necessary by outside plate.
2. For lock with outside securing stud type, slide two outside securing stud into prepared holes on door.

CAUTION:

DO NOT ATTEMPT TO MOUNT LOCK UNIT WITH DOOR CLOSED.

5. ASSEMBLE INSIDE TRIM

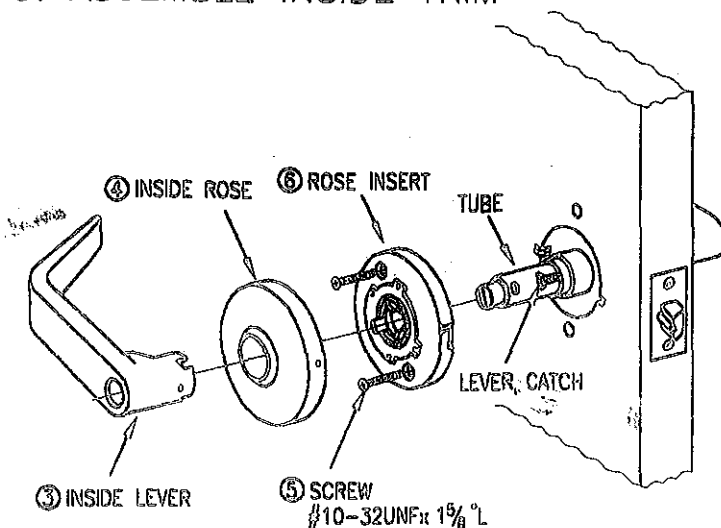

NOTE :

USE WHITE LONGER SCREWS FOR DOOR THICKER THAN $1\frac{5}{8}$ ".

1. Position the screw holes vertically with winder notch at inside diameter in line with lever catch. Then slide onto tube and align rose screw holes with #10-32UNFx $1\frac{5}{8}$ " L screw (5). (See note)
2. Place inside rose (4) onto inside rose insert (6) aligning two lances with recesses in rose insert (6) and turn clockwise to lock as firmly as possible
3. Slide inside lever (3) onto tube. Make certain lever catch on tube is engaged with lever.

6. INSTALL STRIKE

② SCREW
PHILLIPS HD.

① STRIKE

When strike box is not used, recess in door jamb must be deep enough to allow latch bolt to extend to its full free length.

Deadlocking
Plunger

Strike

Deadlocking plunger on latchbolt stops against strike, preventing forcing when door is closed.

7. ADJUST FOR DOOR THICKNESS

Disassemble the outside Lever (fig.2 or fig.3) and take off the outside Rose assembly. Adjust the door thickness by turning the outside plate ⑩ with hand.

APPROXIMATELY 1-1/2 TURNS BACKWARD
FROM MAXIMUM TURN STOPPING POINT
FOR 1-3/8" THICK DOOR.

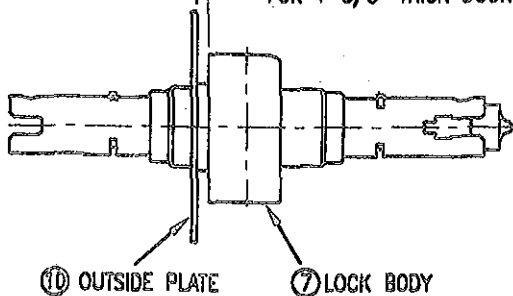

ADJUST TO 3/8"
FOR 1-3/4" THICKNESS
OF DOOR

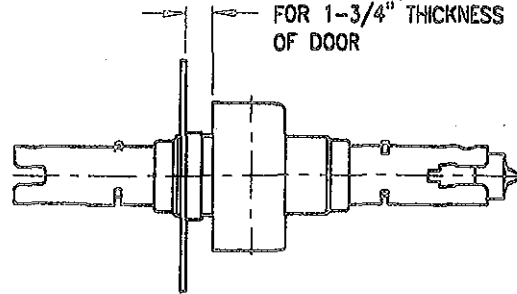

8. REMOVE OUTSIDE LEVER

③ LEVER PULL



② PUSH TOOL

① KEY TURN

(FIG.2)

Keyed locks:
Insert key into cylinder and using pointed end of spanner wrench, or similar tool, place into hole in lever. Turn key approximately 1/4 turn while exerting pressure on wrench until lever catch depresses. Pull off lever and driver.

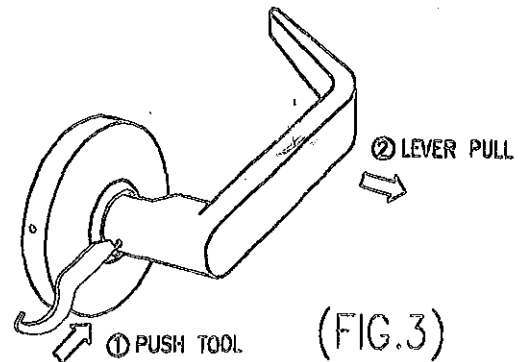

(FIG.3)

Non-keyed locks:
Place pointed end of spanner wrench, or similar tool, into hole in lever. Push in to depress lever catch and remove lever and driver.

9. CYLINDER REMOVAL AND REASSEMBLY

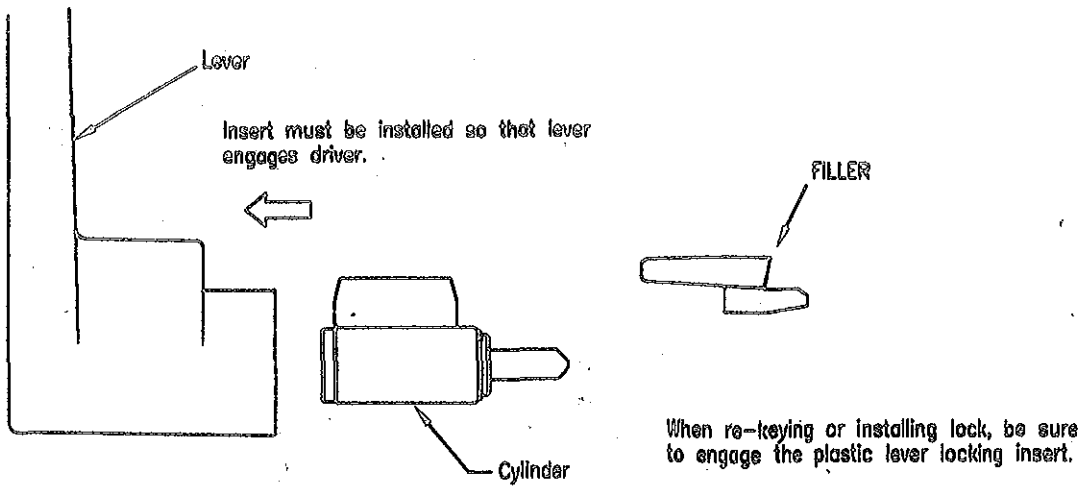

10. INTERCHANGEABLE CORE HOW TO REMOVE CORE

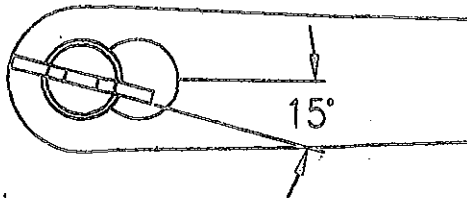

Insert control key and turn 15 degrees to the right until action stops. Pull on key to extract core.

HOW TO REPLACE CORE

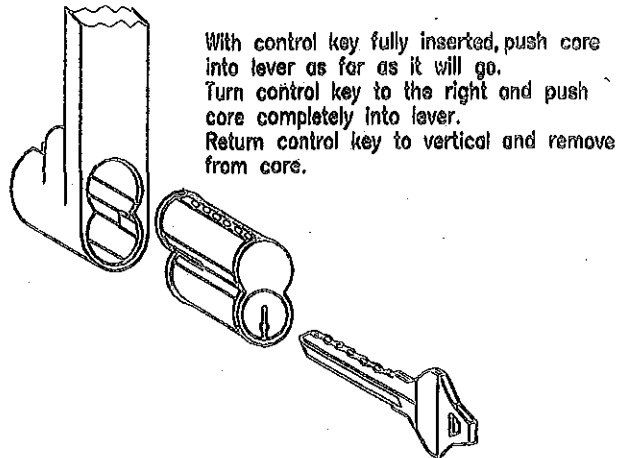

11. CORE AND TAIL-PIECE APPLICATION

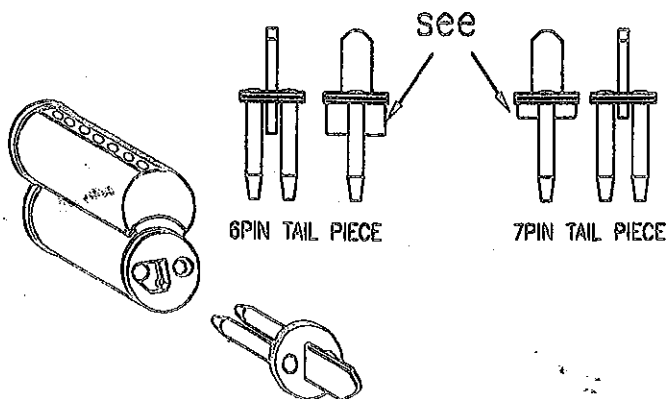

NOTE :
For function only use tail piece.
7pin Tail piece for 7pin core, 6pin Tail piece for 6pin core.

12. DISASSEMBLE INTERCHANGEABLE LEVER

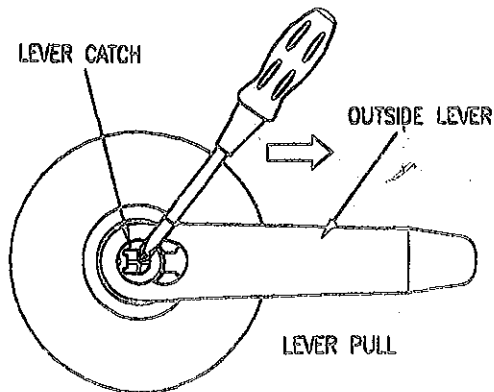

The outside Lever can be disassembled by pulling the outside Lever with pushing the Lever catch by driver through the hole on the outside Lever.

