

INSTALLATION INSTRUCTIONS FOR INTERCONNECTED LOCKSET

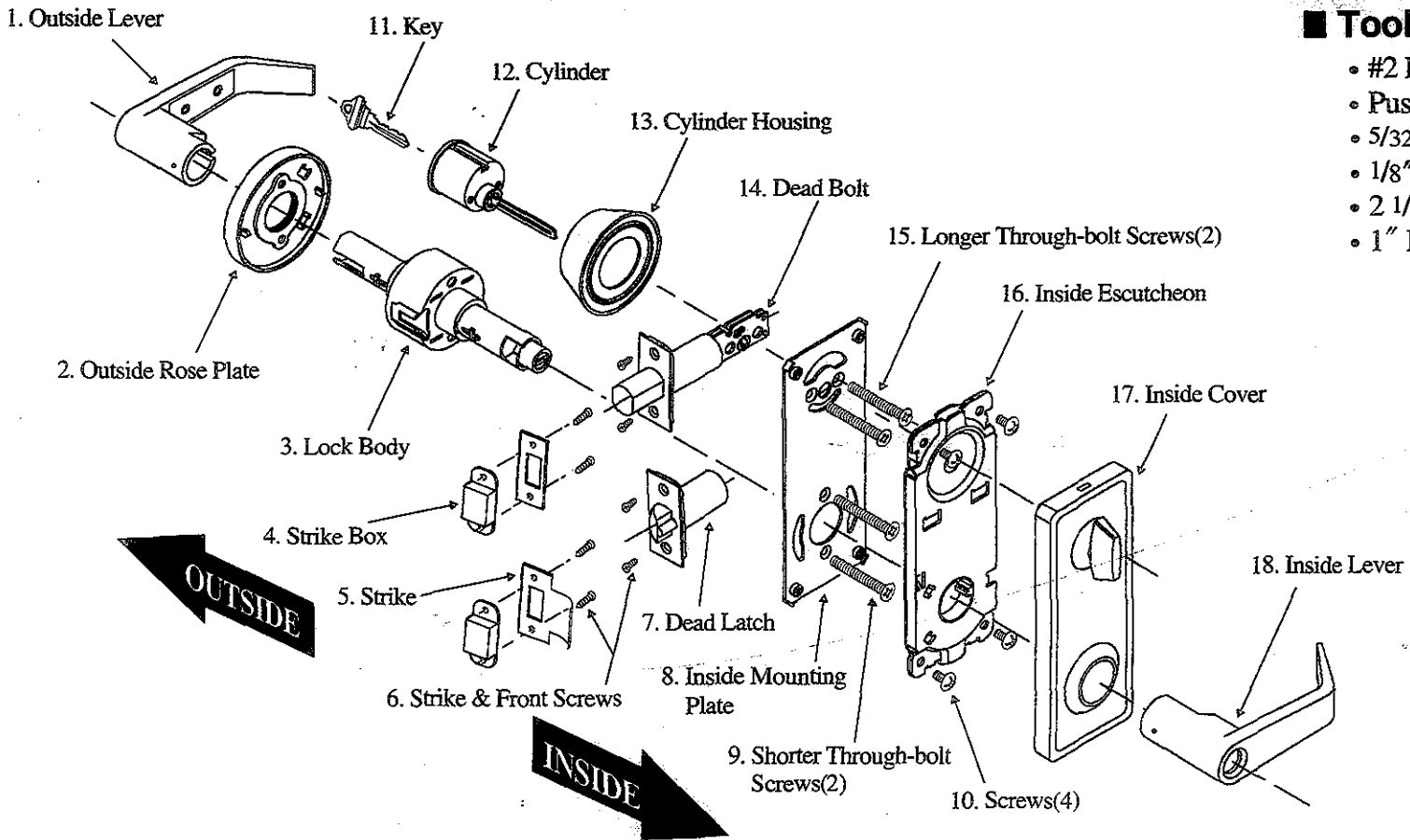

Tools

- #2 Phillips screwdriver
- Push pin(provided)
- 5/32" Drill bit
- 1/8" Drill bit
- 2 1/8" Bore
- 1" Bore

A. Door Prep

1. Hollow metal doors should be properly reinforced for lock support. If support is not provided, contact door manufacturer.
2. For all metal & wood door preparations use attached template.

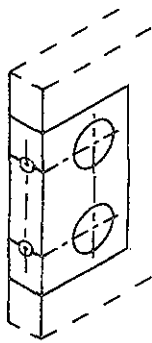

B. Mark and Drill Holes

1. Important - Fold template on high edge of door bevel.
2. Determine backset of the lock (2 3/8" or 2 3/4").

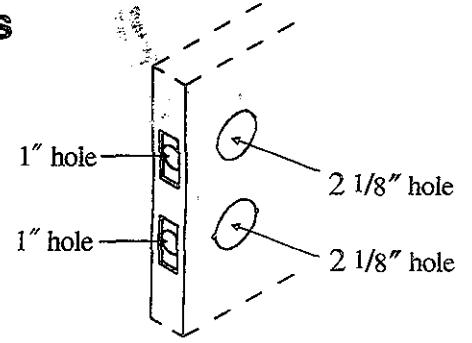

DOOR TEMPLATE

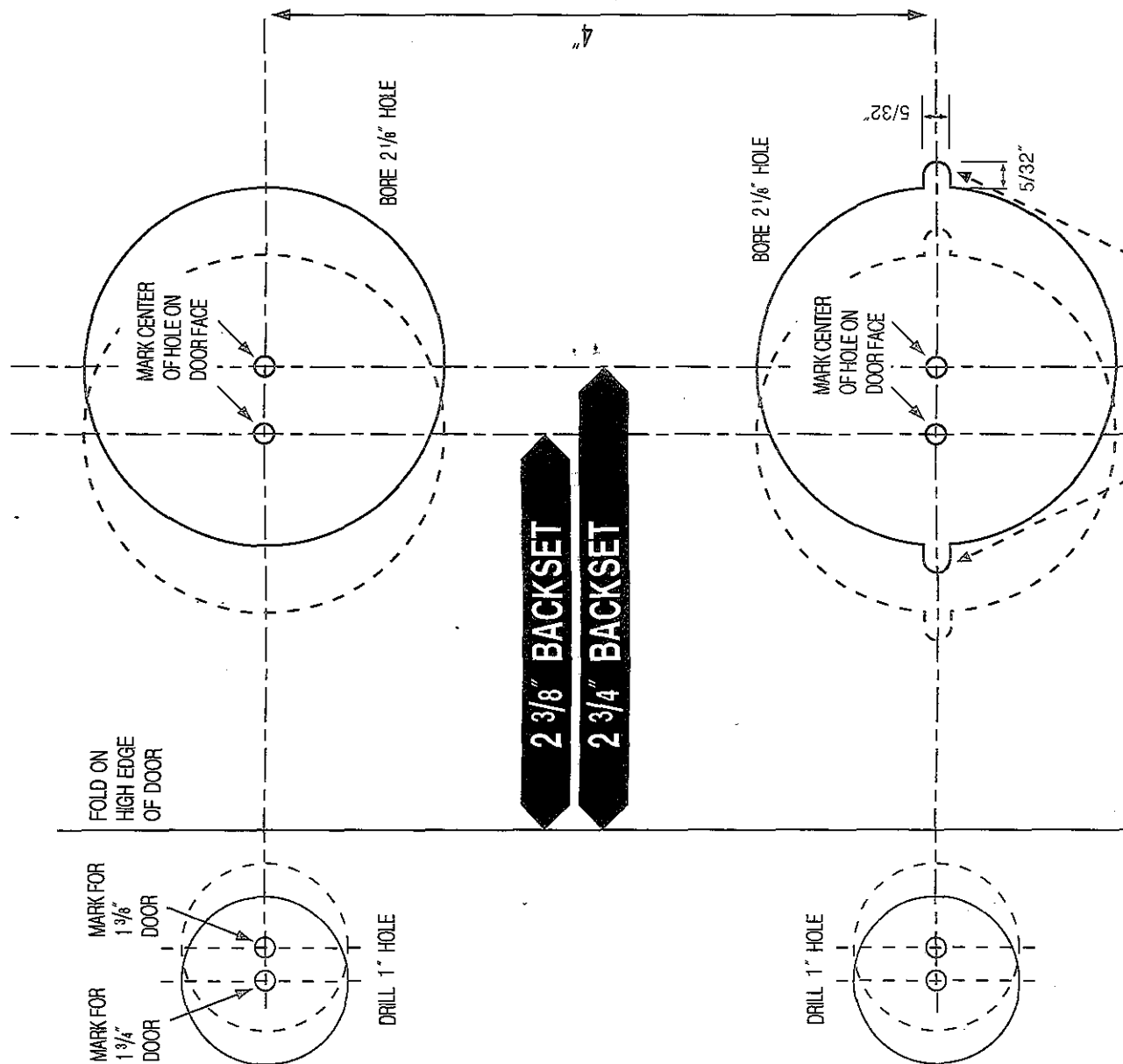

MUST PROVIDE NOTCHES ON DOORS

C. Prep and Install of Strikes

1. Align centerline of latch front and strike.
It is required that the deadlocking latch must stop on strike when door is closed.
2. Use longer reinforcement screws and plate if frame prep is substandard.
3. Install strike and box with two screws.

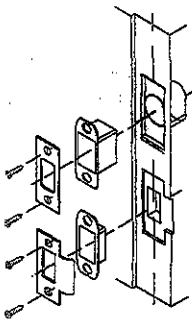

D. Latch & Dead Bolt Installation

1. Insert latch bolt and dead bolt (projected position) as shown.
2. Make sure the backset of the latch and dead bolt align with the backset of the door.
3. Install two screws for each loosely. Tighten after lock is completely installed.

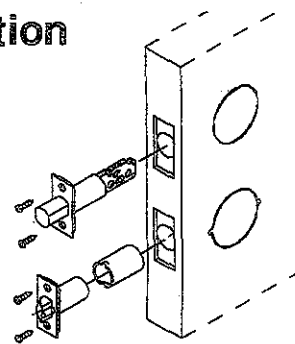

E. Door Thickness Adjustment

1. Lock assembly is preset to fit 1 3/4" (44mm) door thickness.
2. Adjust lock for 1 3/8" Door
 - Inserting key, rotate 45 degrees and hold.
 - Insert push pin and pull off lever.
 - Rotate the outside rose plate clockwise (3 Turns) to center of the lock in the 1 3/8" door thickness.

F. Lock Installation

1. Remove inside lever from lock, using push pin.
2. Install lock assembly into door and engage latch as detailed, per image below.

Latch and lock engagement

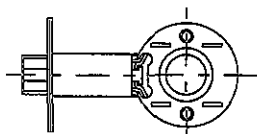

3. Install inside mounting plate with 2 Shorter lock body screws.
4. Install outside deadbolt cylinder assembly, with tailpiece rotated vertically with half circle of tailpiece on top.
5. Inside escutcheon-align the lower driver tab with slot within the lock body, align upper cam slot so that it is vertical.
6. Secure inside escutcheon with 4 screws.
7. Snap on inside cover and inside lever.

