

INSTRUCTIONS FOR INSTALLING FWCVR9800 x 120 CONCEALED VERTICAL ROD EXIT DEVICE FOR WOOD DOOR

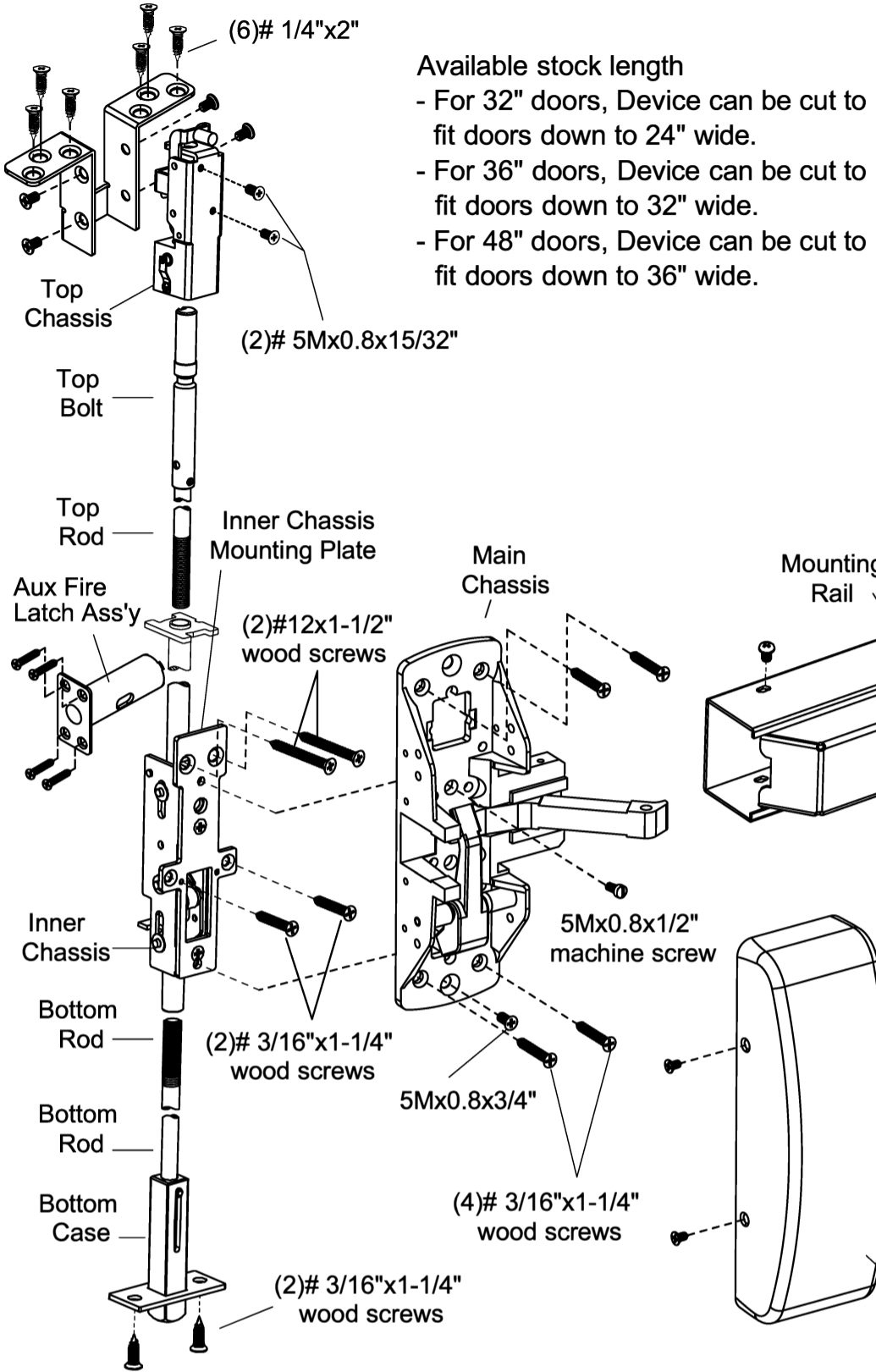

THIS EXIT DEVICE IS HANDED
CHECK HAND OF DEVICE AGAINST APPLICATION

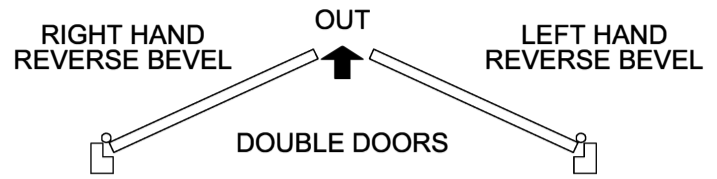

Door Surface must be flush to allow Exit Device rest on flat surface of the door

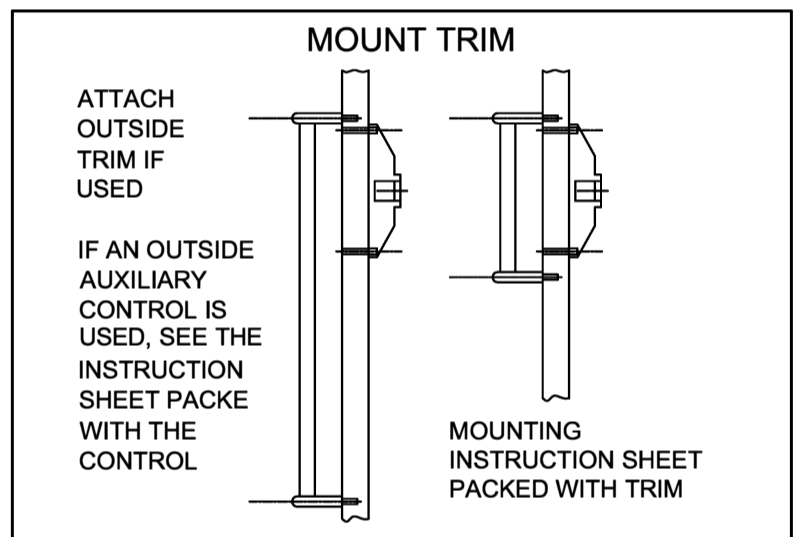
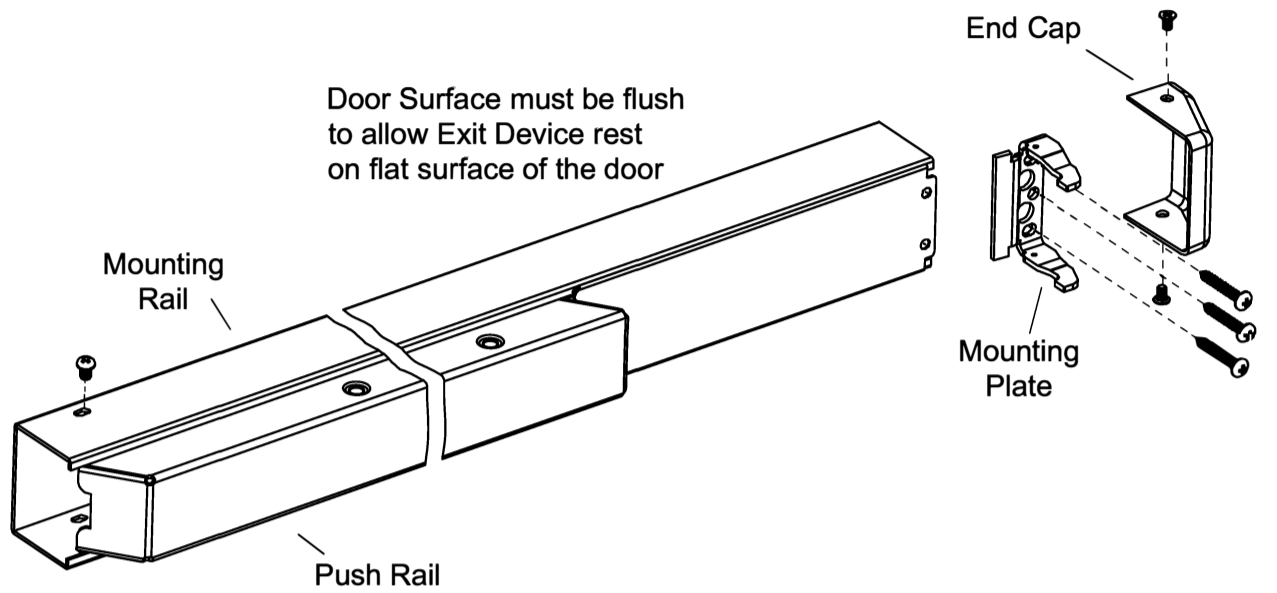

INSTRUCTIONS FOR INSTALLING CAL-ROYAL ESC LEVER TRIM FOR FWCVR9800 SERIES CONCEALED VERTICAL ROD EXIT DEVICE

1. Thru Inner Chassis cutout in the door, insert the extension in the door.
2. Insert Inner chassis in the cutout, and insert reduced end of extension in top threaded bushing on inner chassis, and fasten the rod extension with 1 machine screw.
3. On outside of door thru the cutout, install Plate into extension in the door.
4. Before attaching main chassis and inner chassis to the door, attach esc lever trim to the door with (2) 1/4-20 x 2-3/8" flat head machine screws.
5. Then attach Rail Ass'y to the chassis, and hinge stile end of rail to the door with mounting bracket.

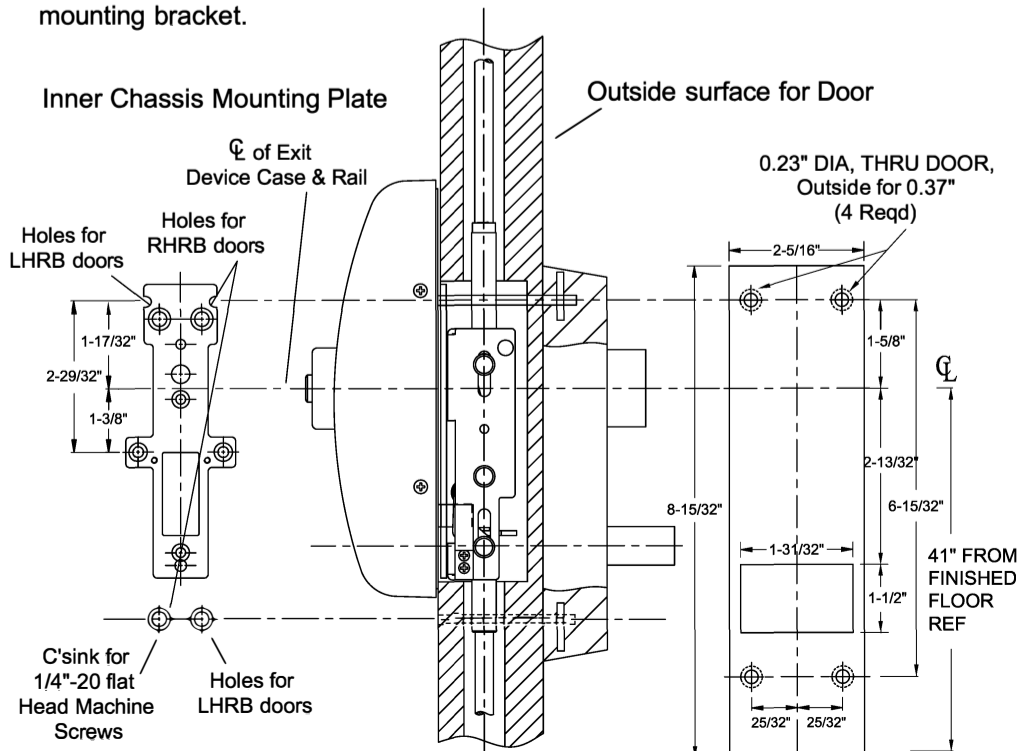

INSTRUCTIONS FOR INSTALLING CAL-ROYAL WOOD DOOR ESC TRIM FWCVR9800 SERIES CONCEALED VERTICAL ROD EXIT DEVICE

1. Thru Inner Chassis cutout in the door, insert the extension in the door.
2. Insert Inner chassis in the cutout, and insert reduced end of extension in top threaded bushing on inner chassis, and fasten the rod extension with 1 machine screw.
3. On outside of door thru the cutout, install Plate into extension in the door.
4. Attach mounting plate to inner chassis with 2 machine screws, then attach mounting plate to the door with 2 wood screws.
5. Attach WD Esc trim to the door. Then attach Rail Ass'y to the chassis, and hinge Stile end of rail to the door with mounting plate.

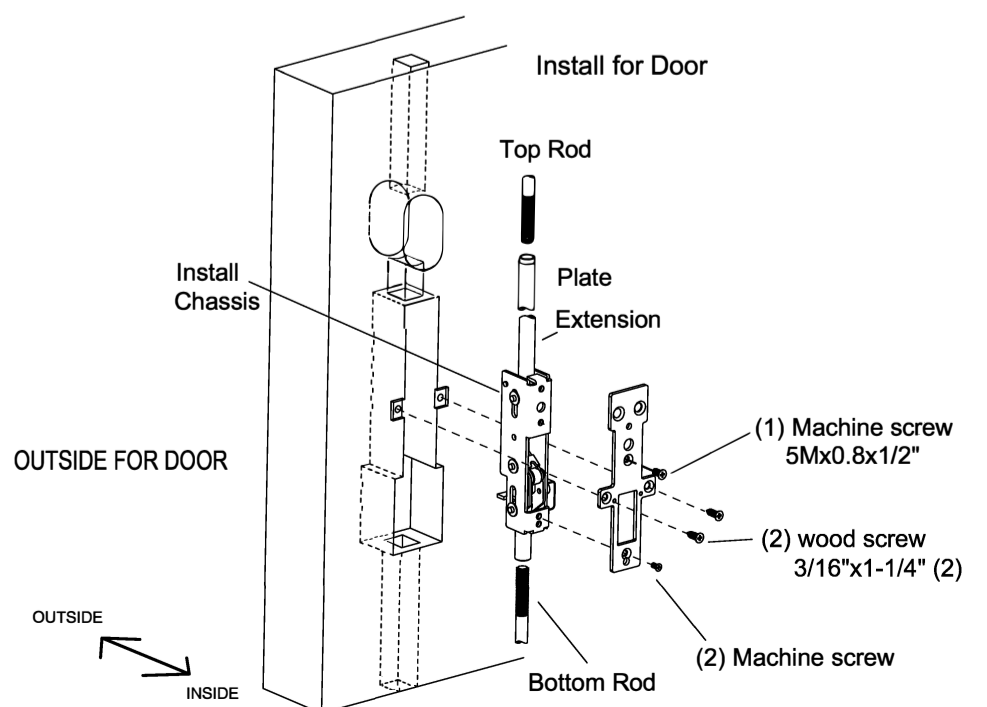

INSTRUCTIONS FOR INSTALLING FWCVR9800 x 120 CONCEALED VERTICAL ROD EXIT DEVICE FOR WOOD DOOR



1. PREPARE DOOR

And Prepare Top and Bottom Strike to Wood frame template

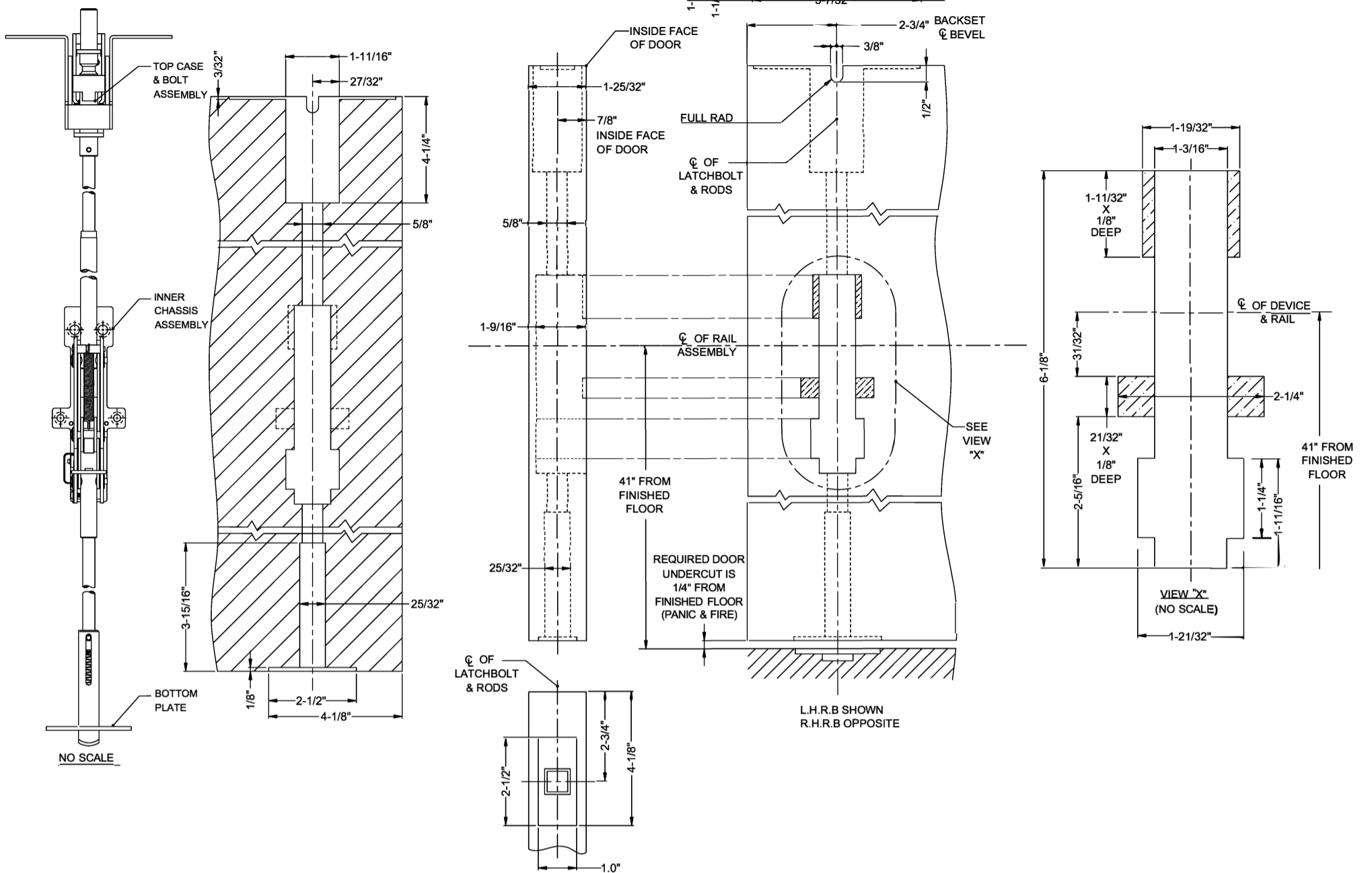

2. MOUNT ROD & CHASSIS

Use Strike Furnished

- Attach inner chassis and its mounting plate to door with 2 wood screw.
- Screw top and bottom rods into inner chassis, and insert this ass'y into the door and fasten inner chassis in place with 2 machine screws.
- Adj top and bottom rods to project bolt 1/2".
- Attach Main Chassis with 1 machine screws to the inner chassis, and 2 machine screw to the inner chassis mounting plate, and 4 wood screws to the door.
- Attach Rail ass'y to chassis with 2 truss head machine screws. Attach the hinge stile end of rail to the door with mounting plate.

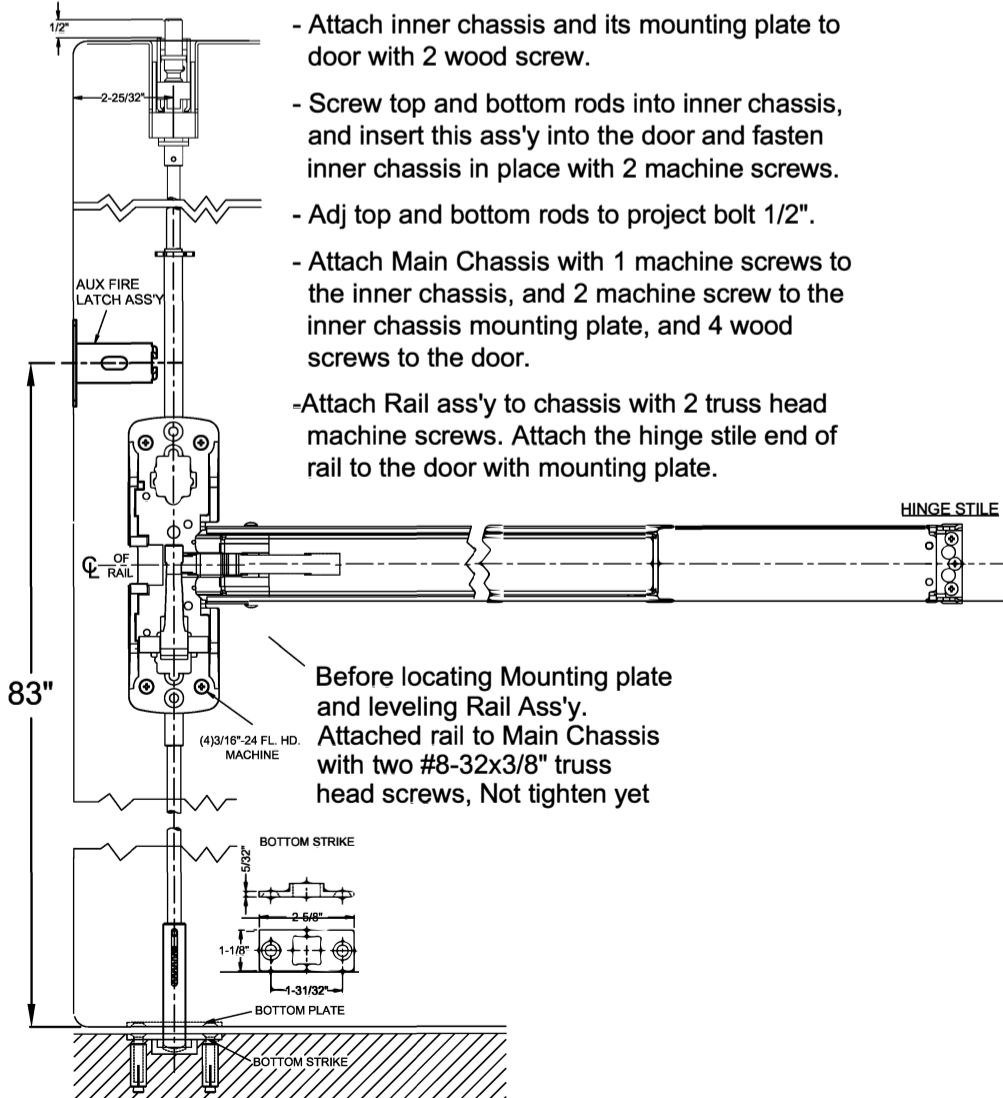

3. MOUNT RAIL ASS'Y

3.1. Determine cut-off dimension "X" by subtracting 1-1/8" from dimension "Y".

3.2. Depress arm into rail opening and slide rail onto chassis.

3.3. With push rail depressed, adj top bolt flush with top of the door, and bottom bolt flush with bottom.

3.4. Insert top chassis into cutout at the top of the door, and attach with six wood screws.

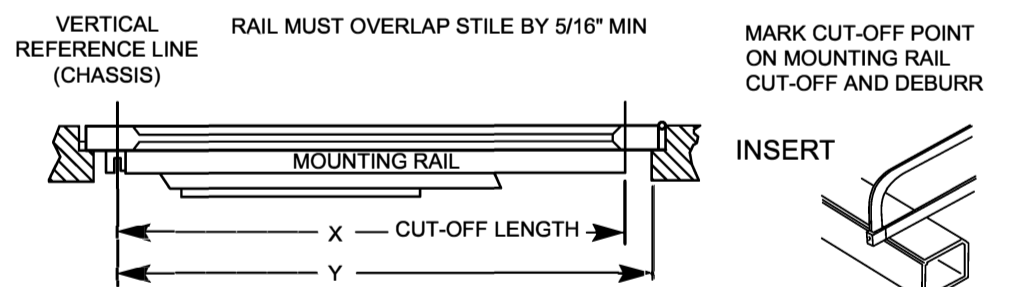

4. ATTACH COVER

- Attach end cap to mounting plate with two cover screws
- Attach cover to chassis with four cover screws.

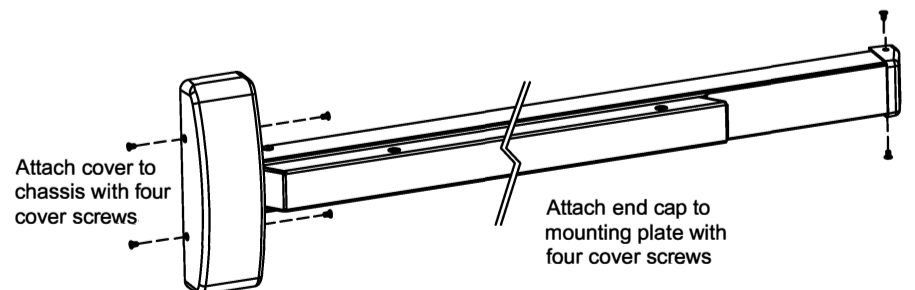

5. OPERATION CHECK

5.1. Depress Push rail, bolt should retract into door.

The latch retractor button should pop out and hold the bolt retracted until button is depressed.

5.2. If button does not pop out, remove top chassis and screw the top rod in one turn. Replace top chassis and repeat abv operation.

TEMPLATE

AUX FIRE LATCH ASSEMBLY FMCVR9800, FWCVR9800, FMCVR7700, FWCVR7700 Fire Vertical Rod Device for 120" Door

DESCRIPTION	QTY.
AUXILIARY FIRE LATCH ASSEMBLY	1
#6X3/6" TYPE AB FLAT HEAD SCREW	4
STRIKE HOLE PLUG	1

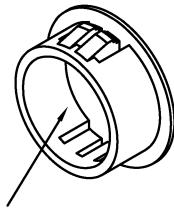

STRIKE HOLE PLUG

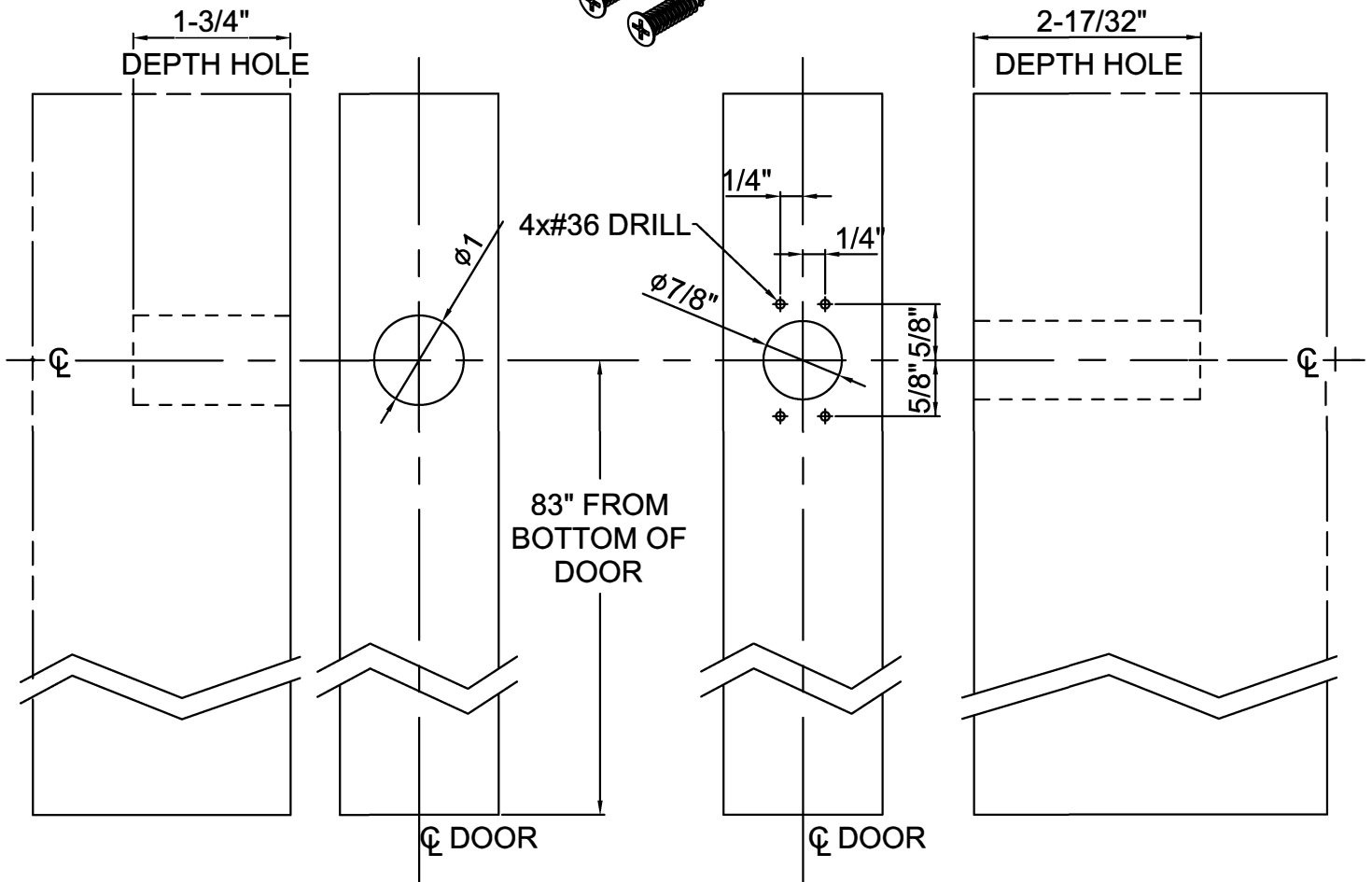
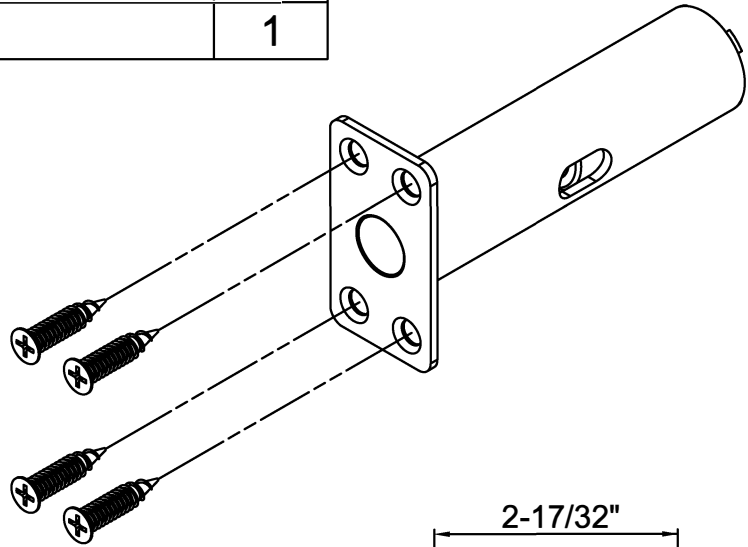

STRIKE HOLE PLUG
DOOR LEAF

AUXILIARY FIRE
LATCH ASSEMBLY
DOOR LEAF