

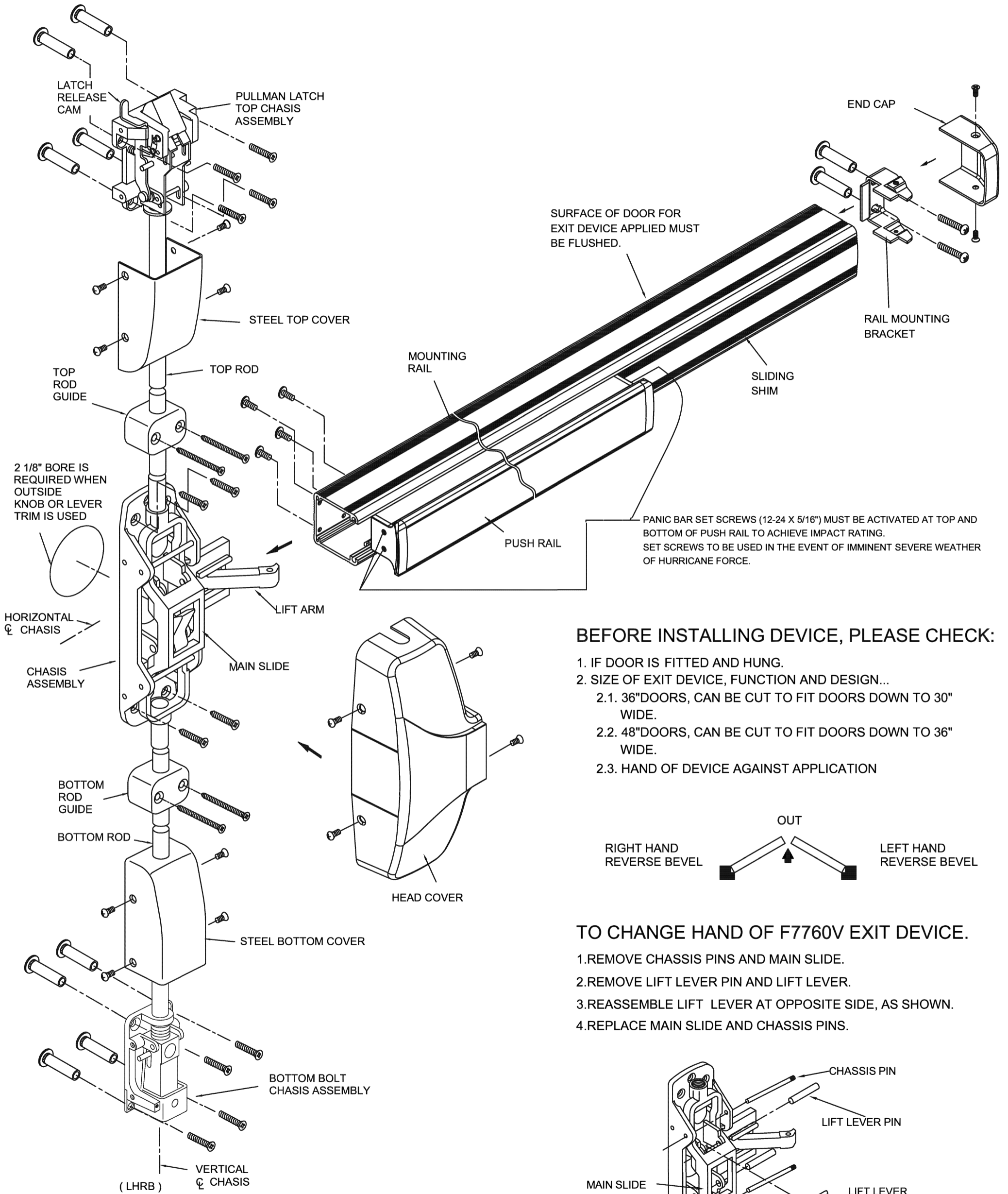

INSTALLATION INSTRUCTIONS FOR F7760V SERIES FIRE VERTICAL ROD EXIT DEVICE.



BEFORE INSTALLING DEVICE, PLEASE CHECK:

1. IF DOOR IS FITTED AND HUNG.
2. SIZE OF EXIT DEVICE, FUNCTION AND DESIGN...
 - 2.1. 36" DOORS, CAN BE CUT TO FIT DOORS DOWN TO 30" WIDE.
 - 2.2. 48" DOORS, CAN BE CUT TO FIT DOORS DOWN TO 36" WIDE.
 - 2.3. HAND OF DEVICE AGAINST APPLICATION

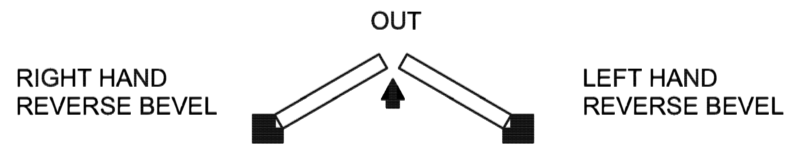

TO CHANGE HAND OF F7760V EXIT DEVICE.

1. REMOVE CHASIS PINS AND MAIN SLIDE.
2. REMOVE LIFT LEVER PIN AND LIFT LEVER.
3. REASSEMBLE LIFT LEVER AT OPPOSITE SIDE, AS SHOWN.
4. REPLACE MAIN SLIDE AND CHASIS PINS.

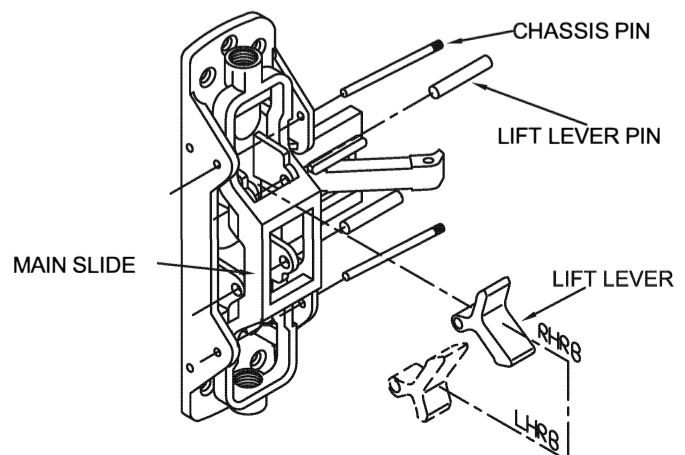

1. MARK VERTICAL AND HORIZONTAL REFERENCE LINE ON DOOR.

DETERMINE BACKSET TO LOCATE VERTICAL REFERENCE LINE.

1. IF LOCK STILE IS 4-1/2" WIDE OR WIDER, BACKSET IS 2-3/4".
2. IF LOCK STILE IS LESS THAN 4-1/2" WIDE, BACKSET IS HALF OF THE EXPOSED WIDTH OF LOCK STILE.

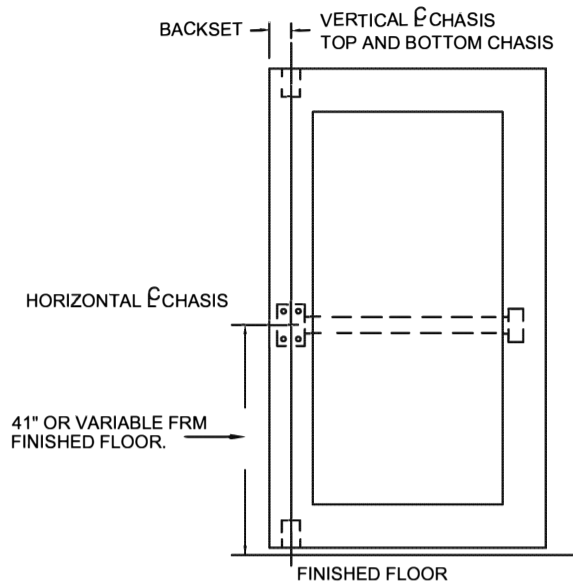

2. PREPARE DOOR

TAPE TEMPLATE ON INSIDE OF DOOR ALONG REFERENCE LINE SPOT AND DRILL HOLE.

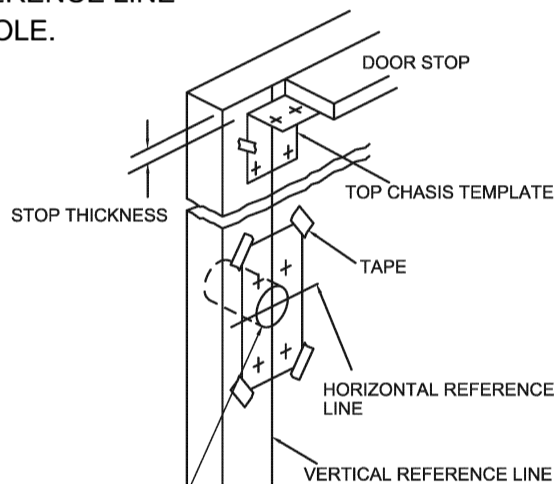

2-1/8" BORE WHEN KNOB AND LEVER TRIM IS USED.

3. APPLY HARDWARE

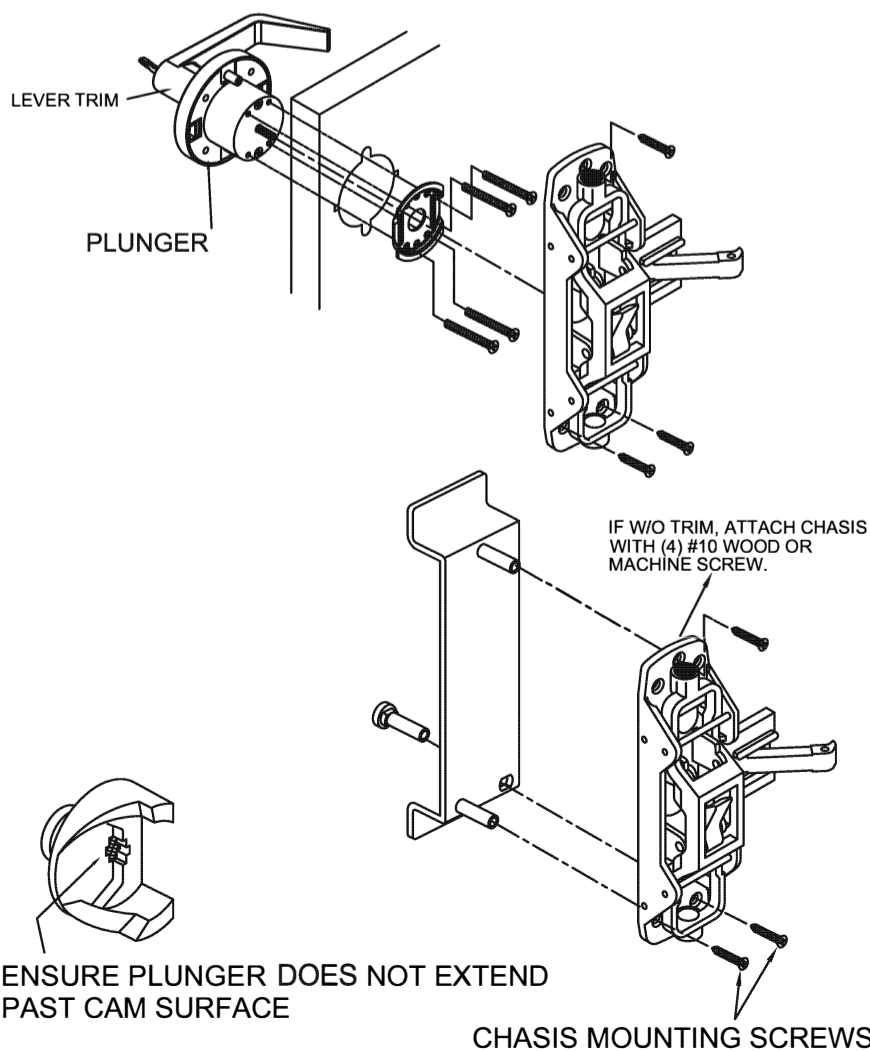

4. ATTACH TOP AND BOTTOM CHASIS

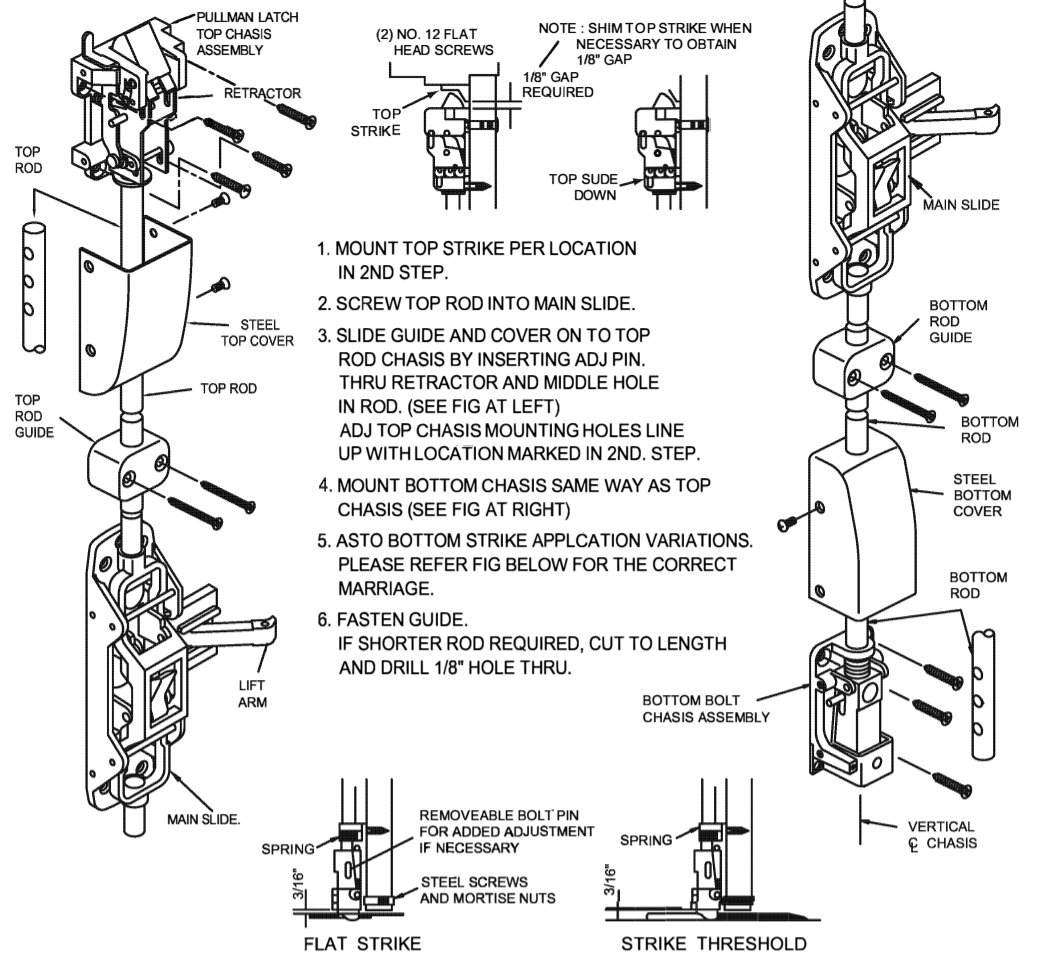

5. APPLY RAIL ASSEMBLY

1. CHECK THE SIZE OF DEVICE, IF CUTTING TO LENGTH IS REQUIRED.
2. DETERMINE CUT OFF LENGTH "X" BY SUBTRACTING 1-3/4" FROM "Y", MARK CUT OFF POINT ON MOUNTING RAIL.

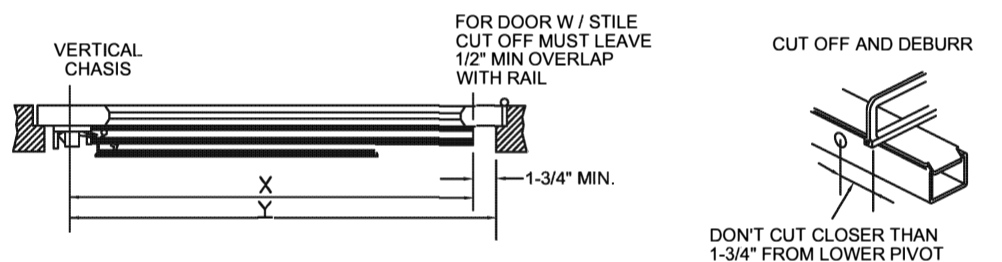

3. DEPRESS ARM INTO RAIL OPENING AND SLIDE RAIL ONTO CHASIS. LEVEL RAIL AND FASTEN CHASIS AND MOUNTING PLATE.

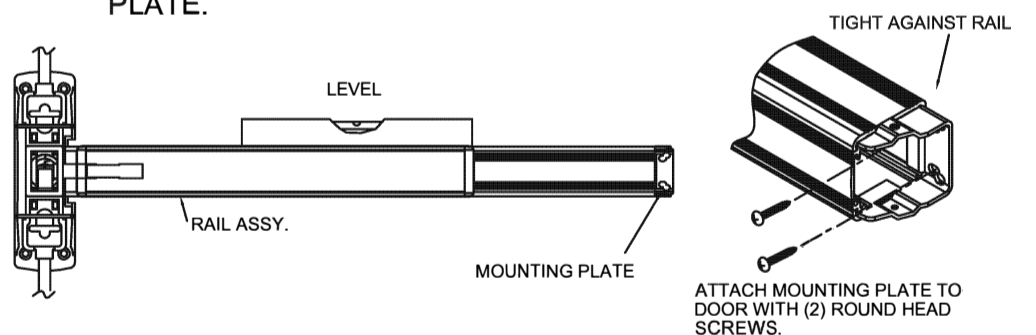

6. APPLY COVER

CHECK FINAL OPERATION OF DEVICE AND ADJUST, THEN FASTEN COVERS.

