

HOW TO CHANGE HANDING

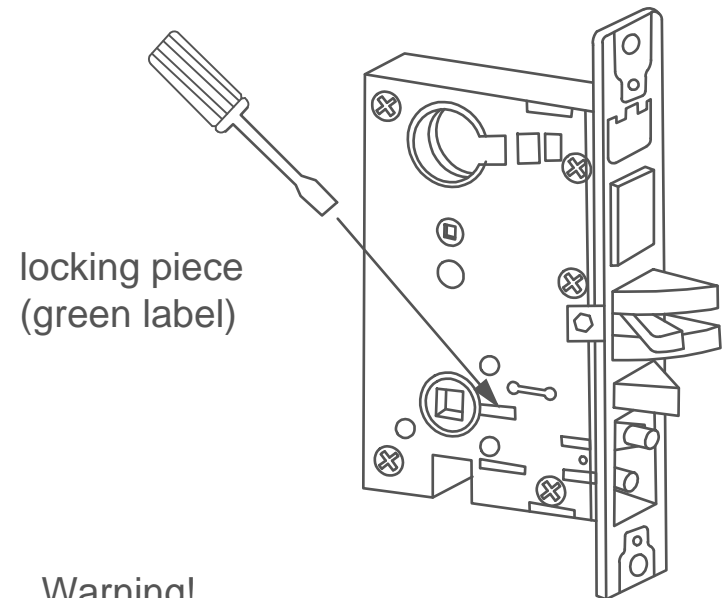

If it is necessary to change handing, the instruction is as follows.

1. Use Hex Key to unfasten the screw in the hole behind latch bolt (green label).
2. Pull latchbolt out until it is entirely away from lock case.
3. Rotate latchbolt to adjust handing.(see page 3)
4. Fasten the screw tightly into the hole and glue with Threadlocker (Loctite 242).
5. Use screwdriver flat head that fit on locking piece (green label) Push to Front Side.(See illustration on page 2)
6. Handing is completely reversed.

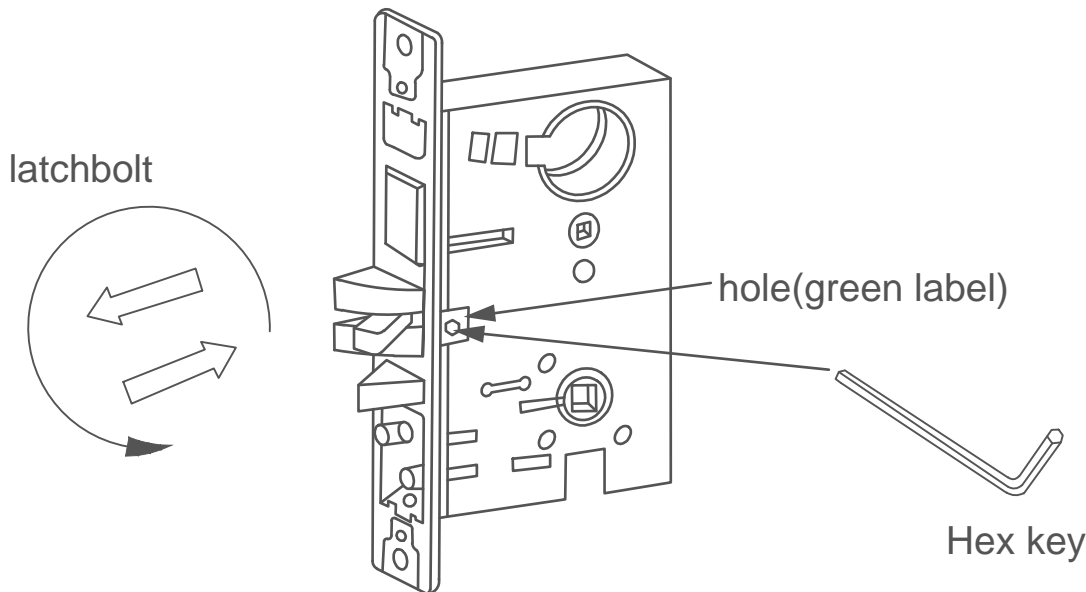

Warning!
Please read the instruction on the installation guide about the correct position of spring cage.

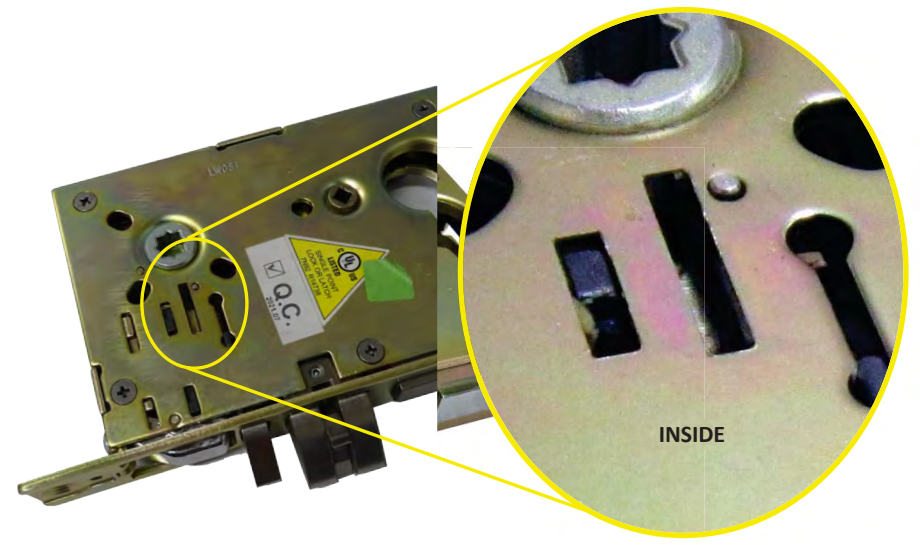
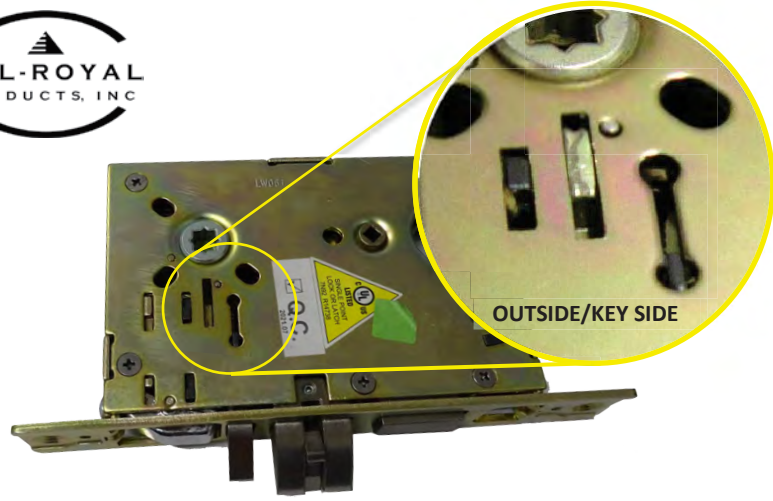

HOW TO REVERSE LOCKING PIECE FROM FLUSHED SIDE TO HOLLOW SIDE: Use a tool, preferably a flathead screw driver that will fit into the locking piece slot (FIGURE 1). Push the locking piece down (FIGURE 2).

1

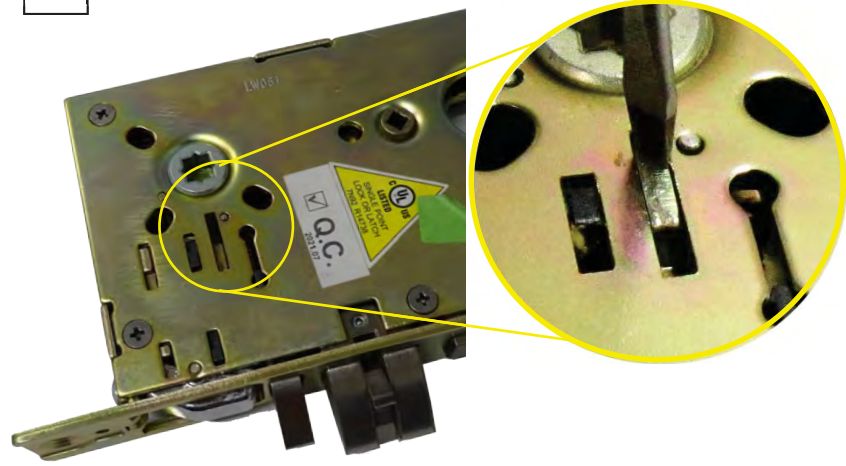

2

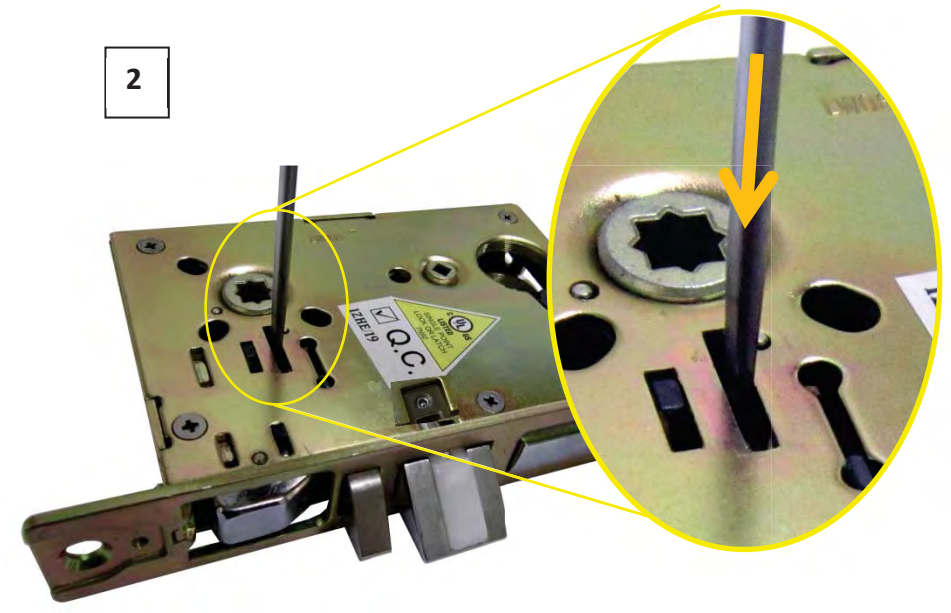

HOW TO REVERSE LATCH



1

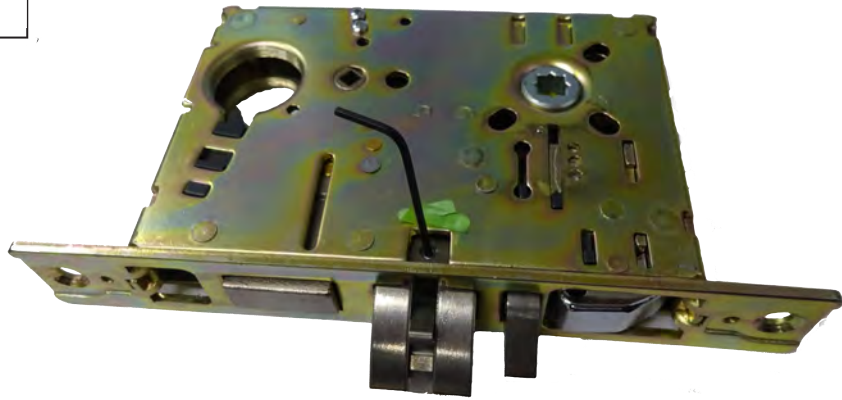

2



3

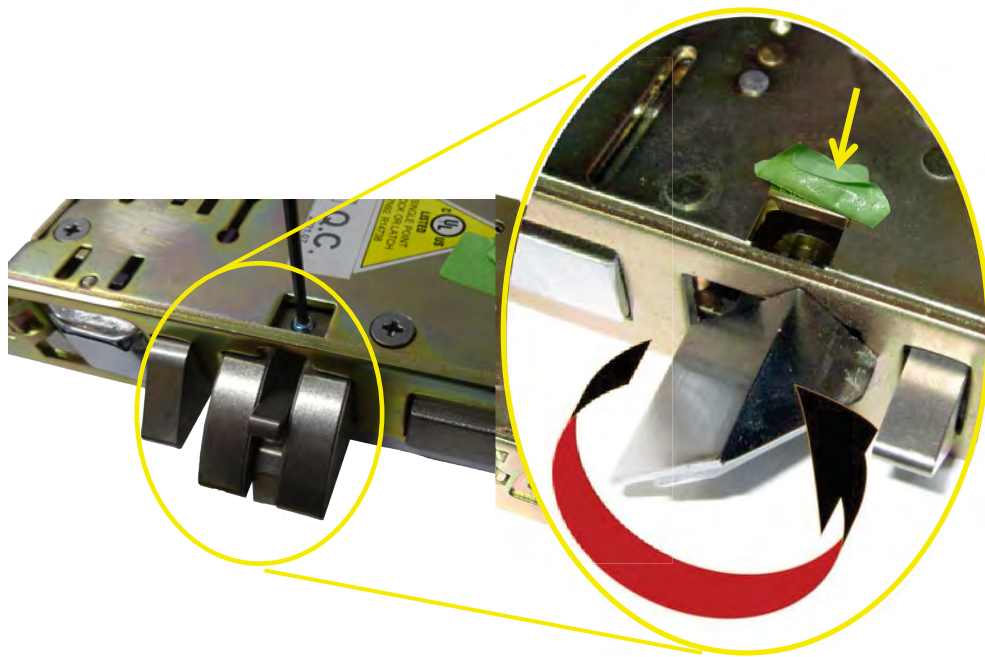

4

