

# Installation manual for SDLP-RND

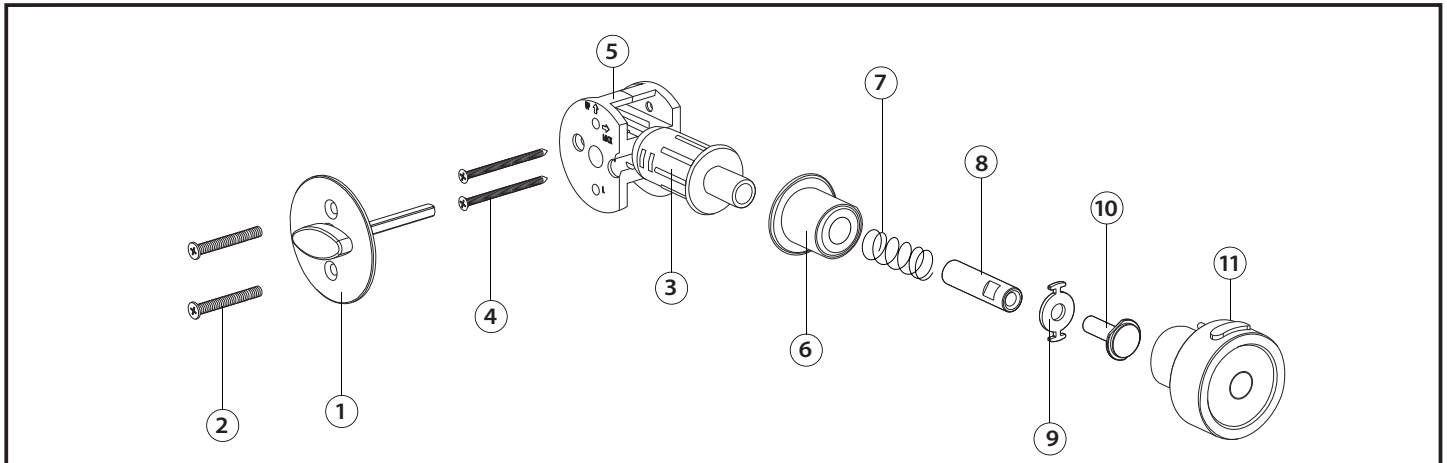

Item	No.	Description
Trim Parts	1	Face Fixing Trim with Spindle
	2	M4 x 45 Slotted Head Screws
Lock	3	Barn Door Lock
	4	ST3.5 x 50 Wood Screws
	5	Lock Bracket
Strike	6	Dust Proof Strike
	7	Spring
	8	Sleeve
	9	Washer
Others	10	Screw
	11	Button

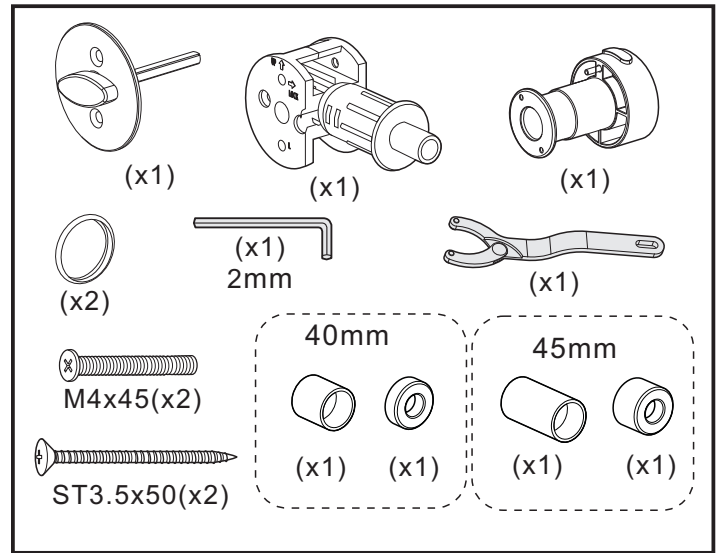
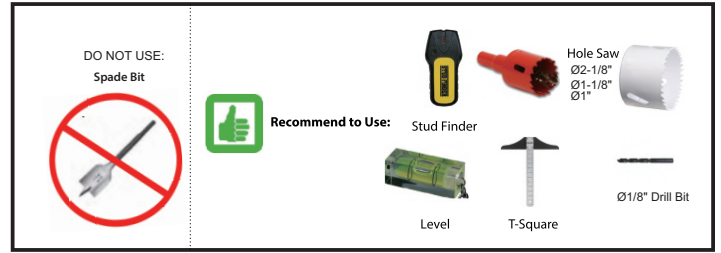
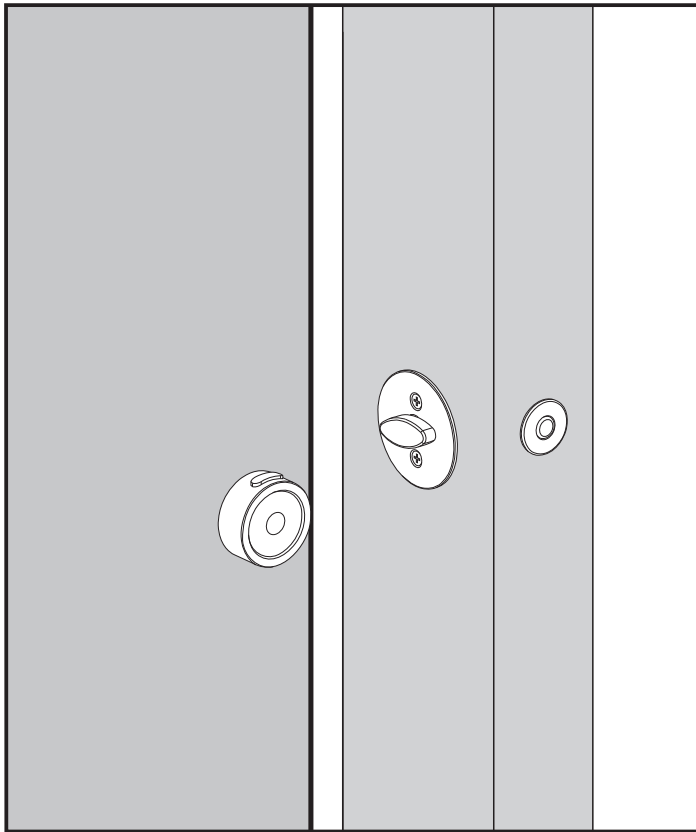
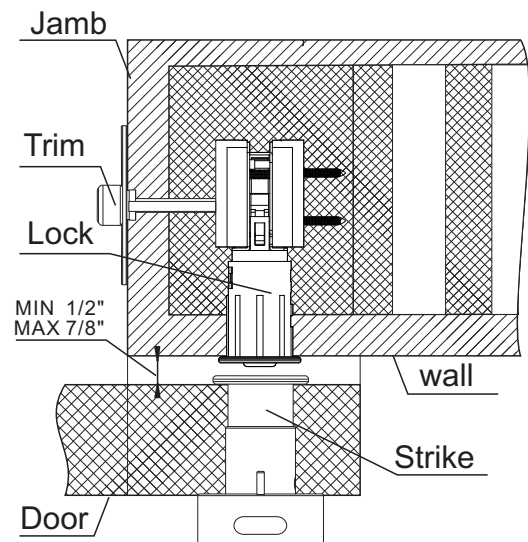

1

Remove Barn Door. Use template to mark pilot hole.

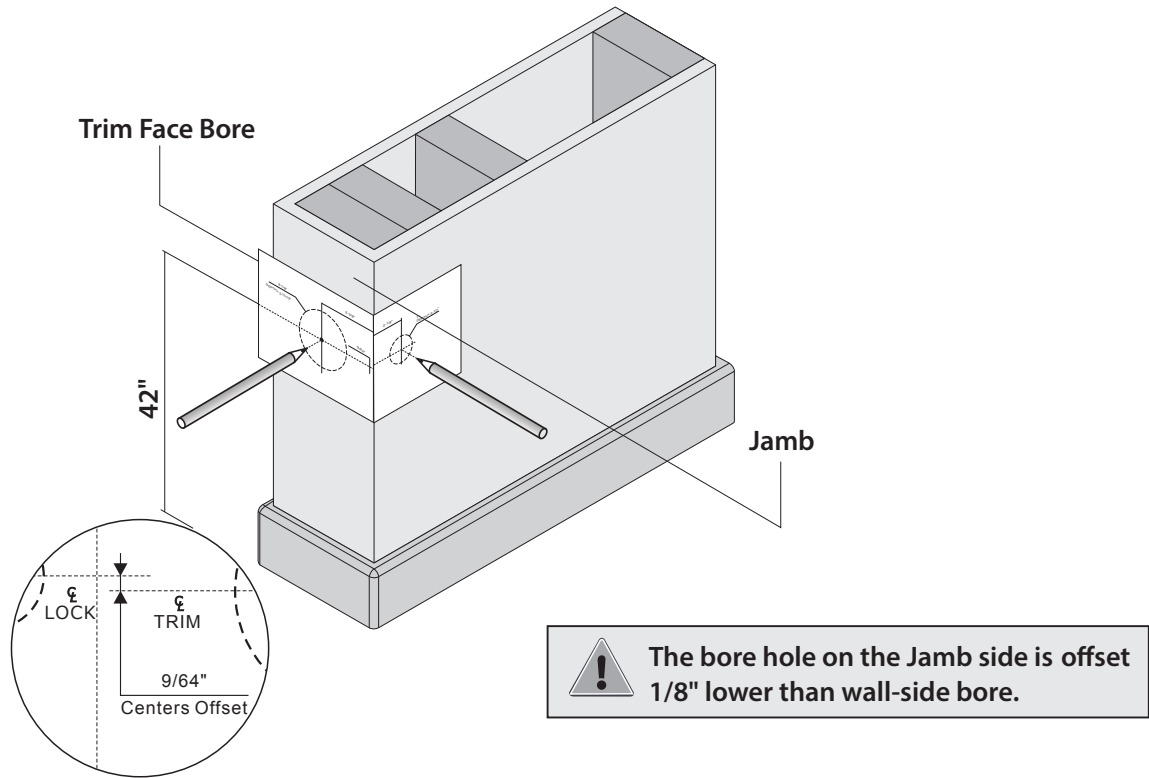

2

1. With a  $\text{Ø}2\text{-}1/8"$  hole saw, depth  $2\text{-}13/16"$

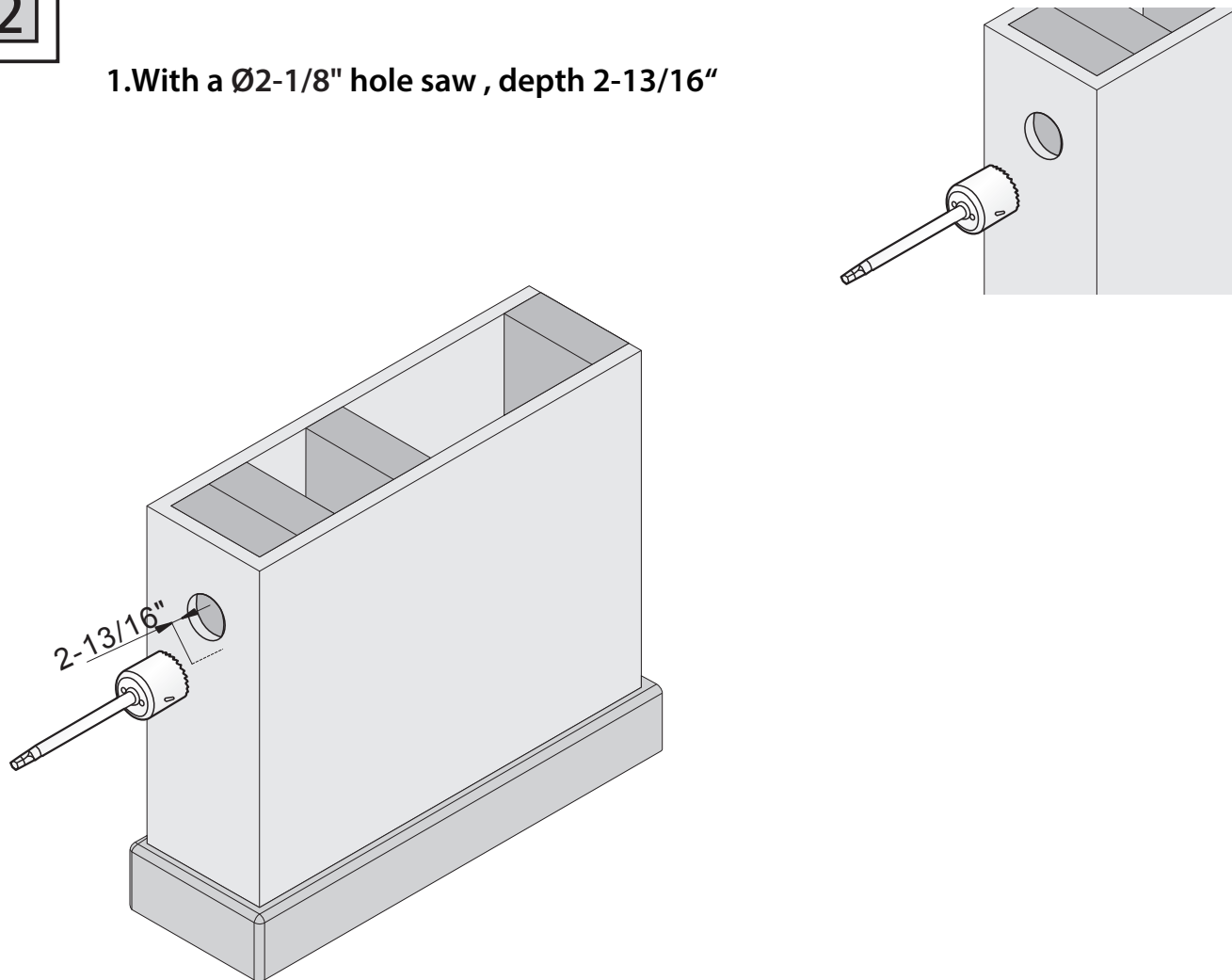

**3**

1. Double check lock bore distance from Step 1. Refer to template markings to ensure both lock and strike pilot holes are within door overlap requirements. Keep 3/8" safety margin to edges.

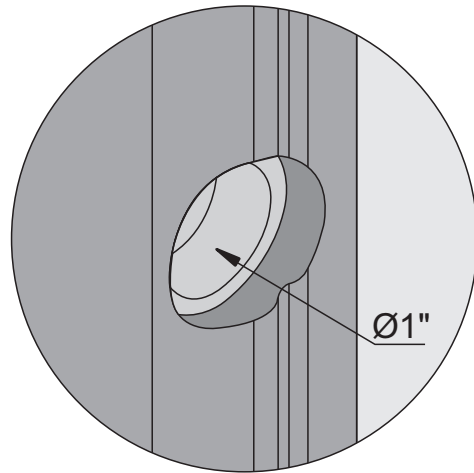
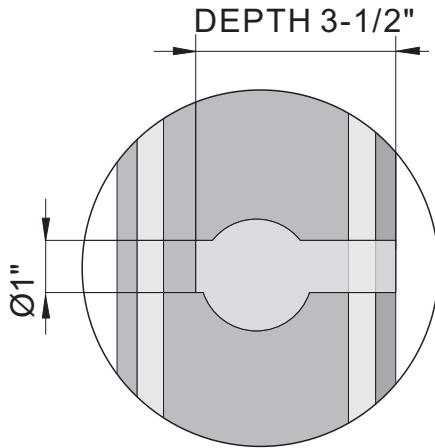
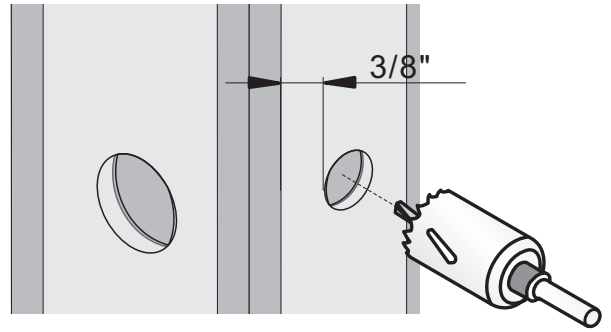

Do not drill too deep, you may damage the wall on the other side.

**4**

A) For drywall and casing less than 1-5/8":

4.1) Insert bracket into trim bore

4.2) Insert lock bolt into lock bore and fit into bracket slot.

1

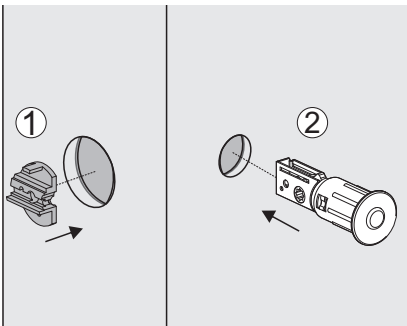

2

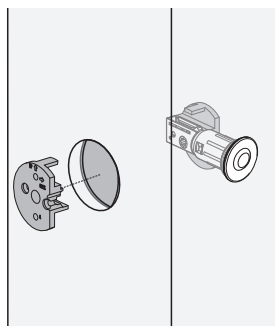

ARROW SHOULD POINT UP

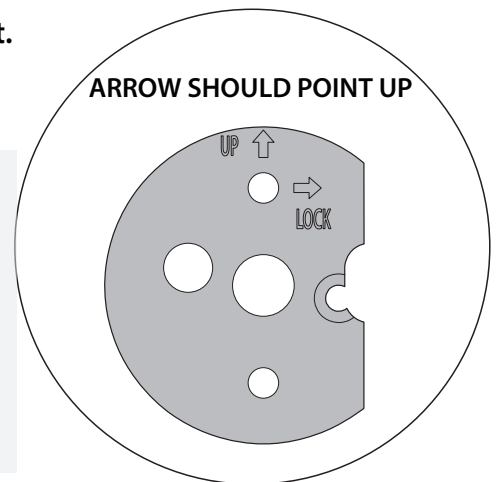

**TIP:** Before drilling, cover area around the bore hole with masking tape; test bolt retraction; if not smooth, troubleshoot as follows:

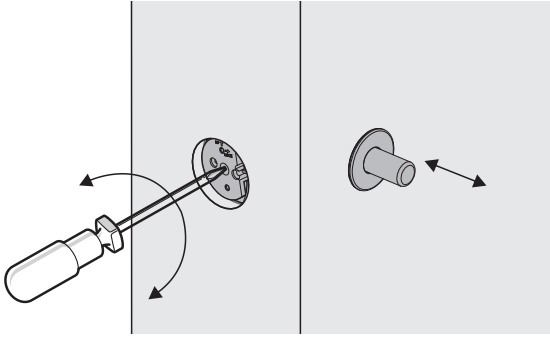

- Check  $\text{Ø}2\text{-}1/8\text{'}$  trim bore dimensions
- Ensure hole is free of debris
- Make sure 1" lock bore is perpendicular to trim bore
- Check lock by removing it from bore and throwing the bolt. Adjust wall prep as needed

**4.5) Fasten the two wood screws inside the trim bore hole through lock body and into wood stud.**

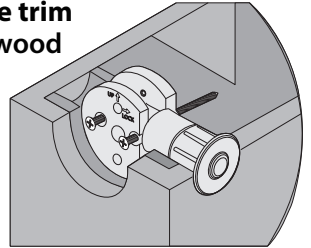

**5**

**1. Cut spindle and screw to accommodate wall side backset.**

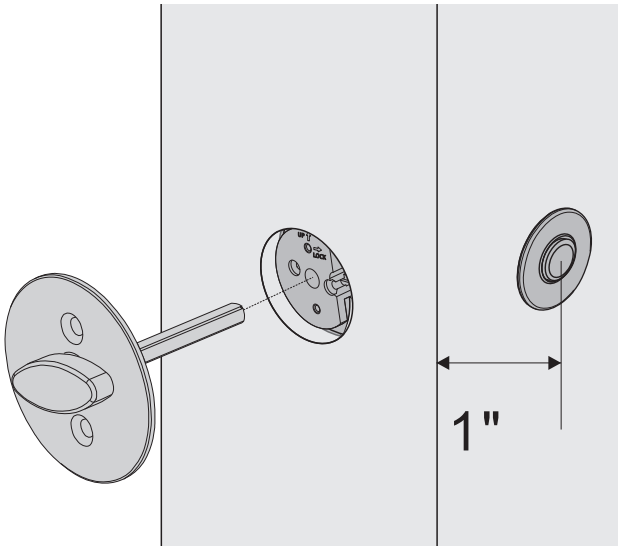

**2. Insert trim into spindle hole. Use thumb turn to test lock bolt movement.**

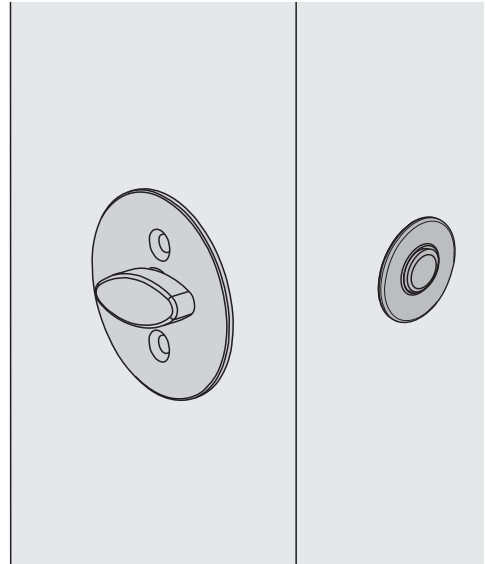

**3. Fasten trim screws until trim is tight to jamb surface.**

**NOTE:** Do not over tighten.

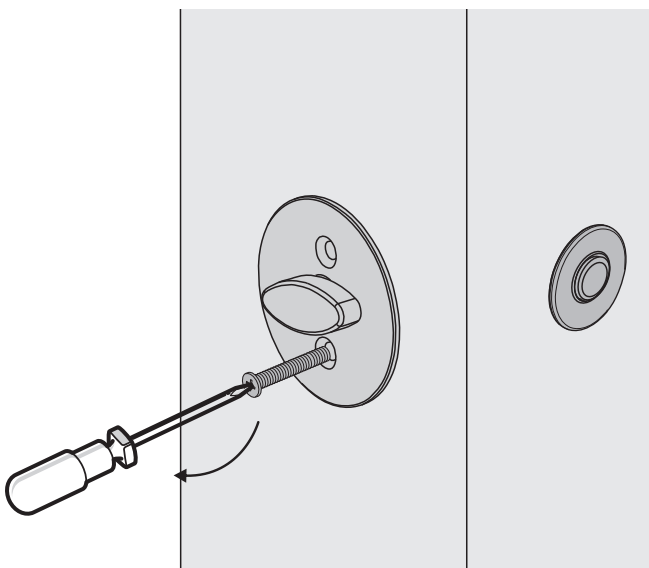

1. Move the Barn Door to the Closed position; throw the lock bolt to mark the exact strike center position. Make sure this location is minimum 1-1/2" to the edge of the door.

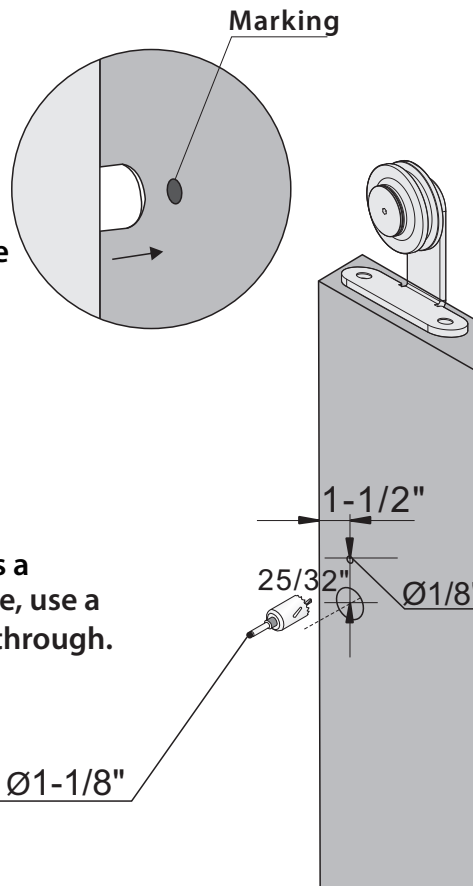

2. Using the strike center position as a guide, With the pilot hole as guide, use a 1-1/8" diameter hole saw to drill through.

Ø1-1/8"

**Note:** Standard Barn Door to wall clearance is approximately 7/8" to 1/2". Install additional spacer as needed behind the strike faceplate if the door to wall clearance is over 1/2". Additional spacers can support maximum clearance of 7/8" between door and wall.

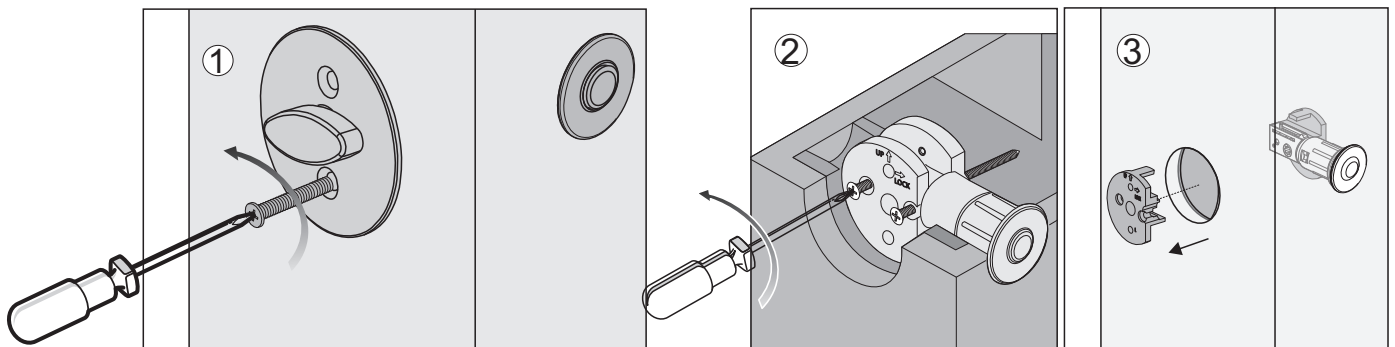
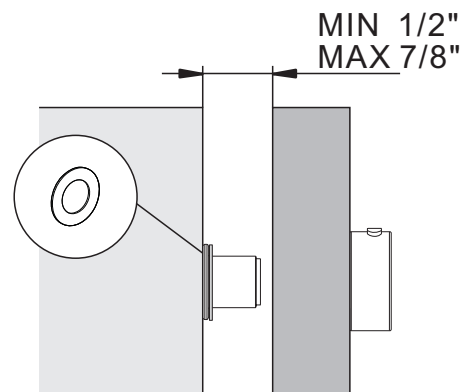

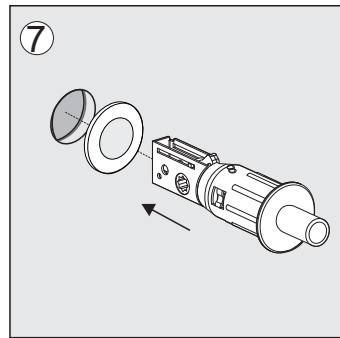
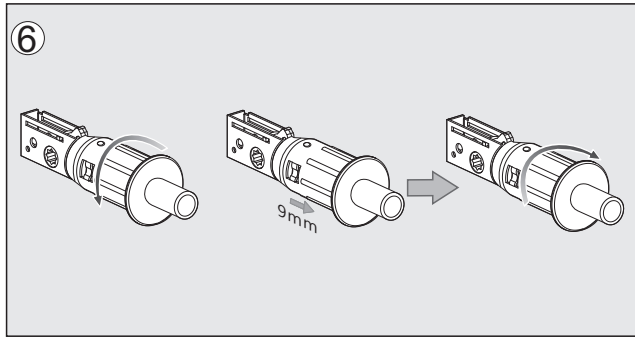
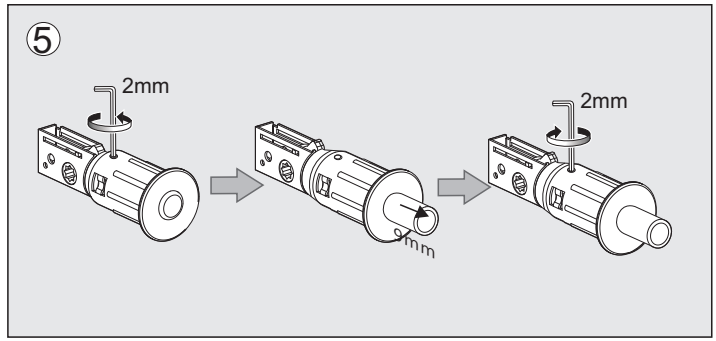
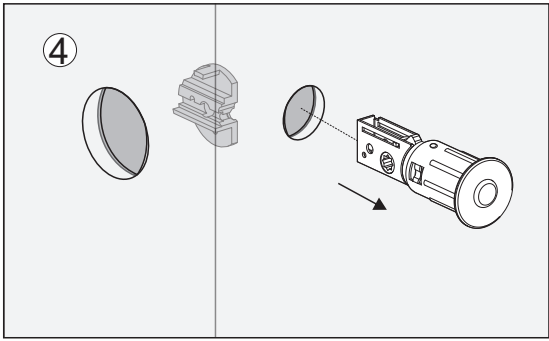

**7**

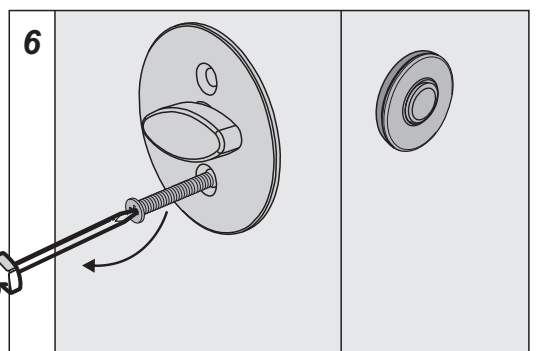
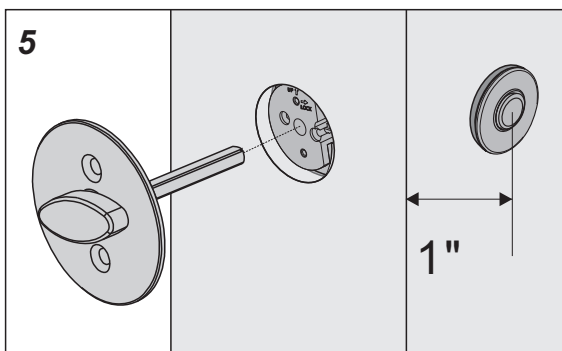
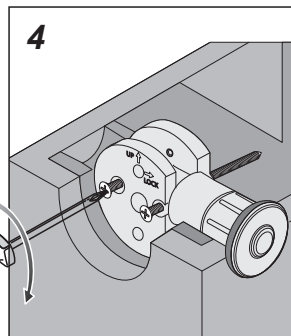
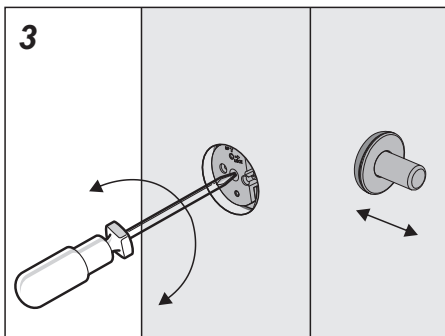
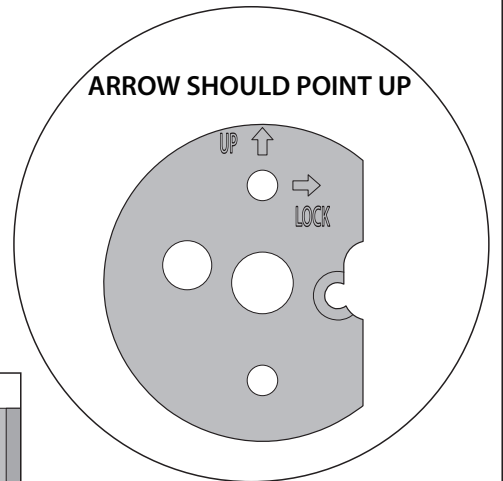
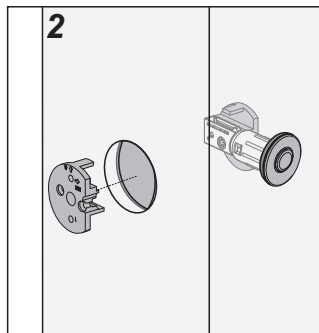
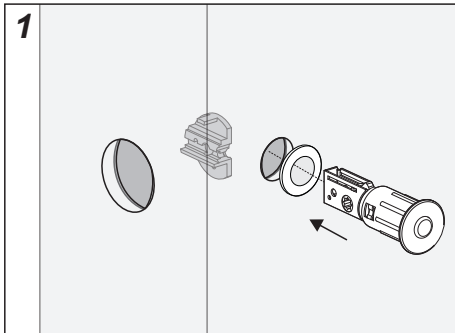

When the width of the door is 35mm:

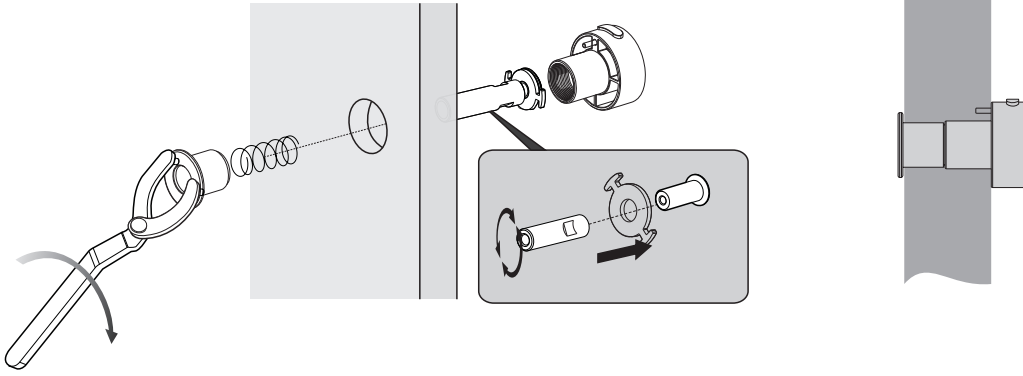

When the width of the door is 40mm:

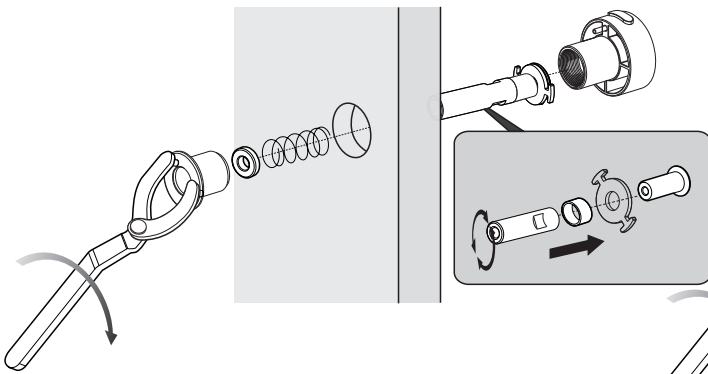

When the width of the door is 45mm:

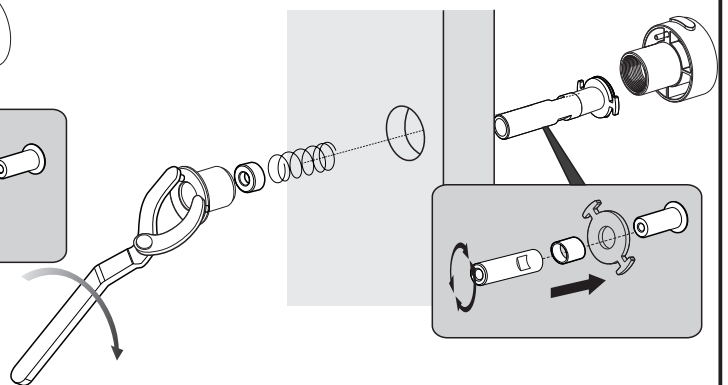

**4. Install break-away screw and tighten with Allen wrench. DO NOT OVER TIGHTEN.**

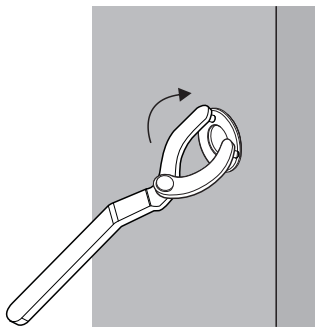

**5. Push the button on top and use a screw driver to push through center hole on release to push lock bolt back and unlock the door.**

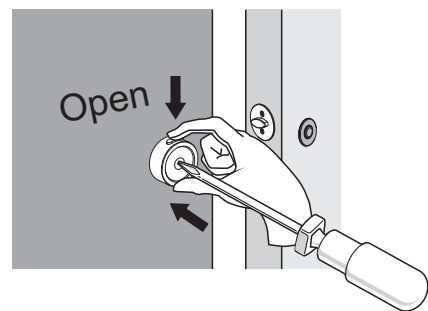

**use a screw driver or a tool that is thin enough to go through the hole in case of emergency.**