

3D INVISIBLE HINGES

100% Made in Italy



3D INVISIBLE HINGES

MAIN FEATURES

- » Zinc Alloy manufactured for Oxidation Resistance
- » Durable Galvanized Steel Covers to conceal the screws
- » Used for Wood and Hollow Metal Doors
- » **Easy 3D Adjusting System or Fixed**
- » Easy Installation and Maintenance Free
- » Complete Reversibility (same slot on the door and the frame)
- » Total Recessed Hinge Body (door and frame gap is very small)
- » **UL Listed for 2-Hour Fire Rated Doors**
- » **European Standard EN1634-1 for 120-Minute Fire Doors**
- » **CE Certified for 200,000 Opening / Closing Cycles**
- » **100% Made in Italy**
- » Elegant Minimalistic Design that is available in **US1, US4, US10B, US14, US15, US26, US26D** and US28 finishes with no visible screws



CR3D62

Dimensions: 6 5/16" x 1 1/4"
(160 x 32 mm)

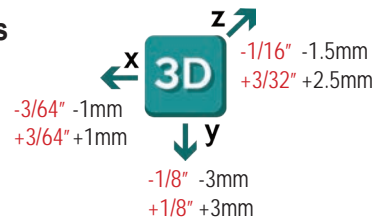

TECHNICAL SPECIFICATIONS:

- 180° Fluid Opening
- 1 1/2" (38mm) minimum door thickness
- Overall Length: 6 5/16" (160mm)
- Width (frame part): 1 1/4" (32mm)
- Width (door part): 1 1/4" (32mm)
- Depth: 1 1/8" (29mm)
- Load Capacity: 3 or 4 Hinges - 120kg (265lbs)
2 Hinges - 80kg (177lbs)
- Fire Proof Min. : EI-120'

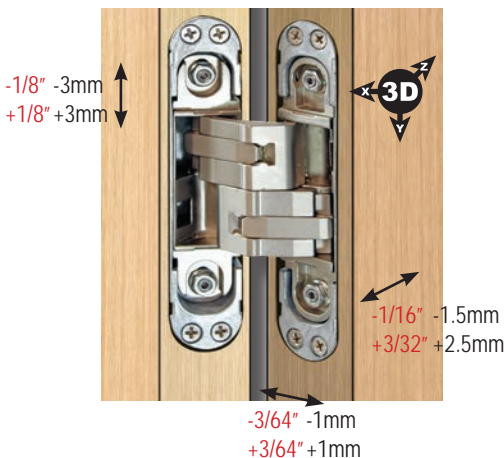
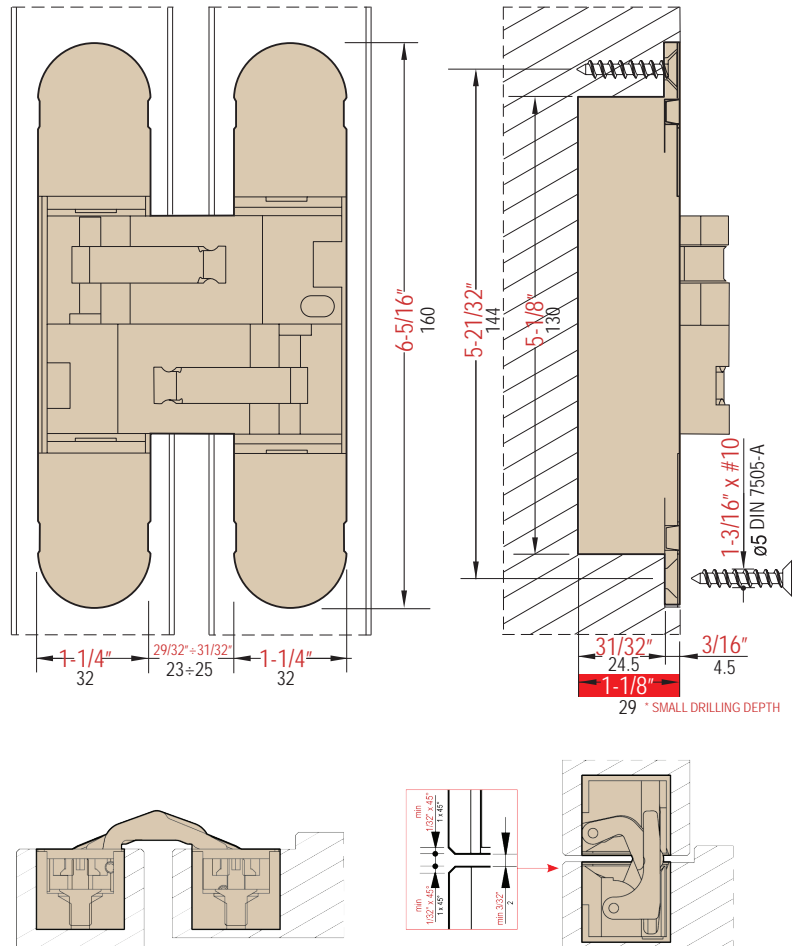

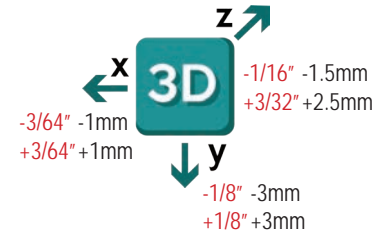
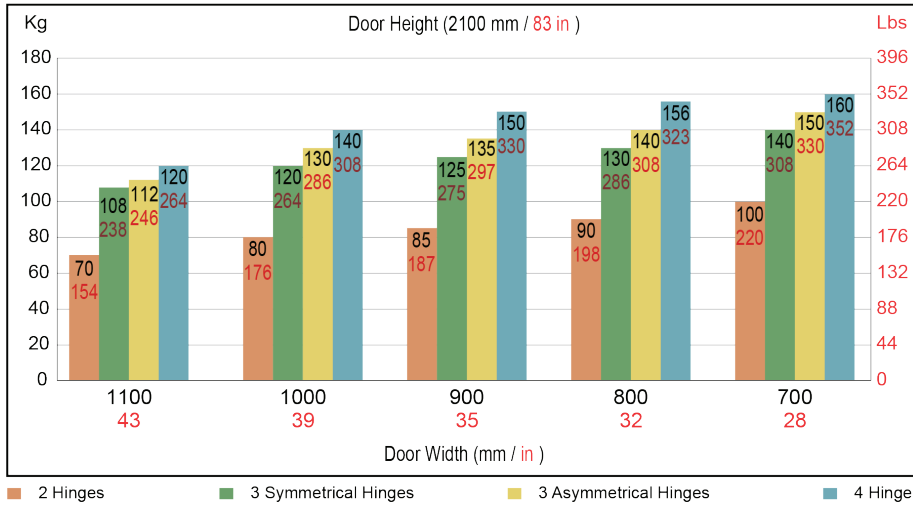

Reversible for doors from:
1 1/2" (38mm) to 1 13/16" (46mm)

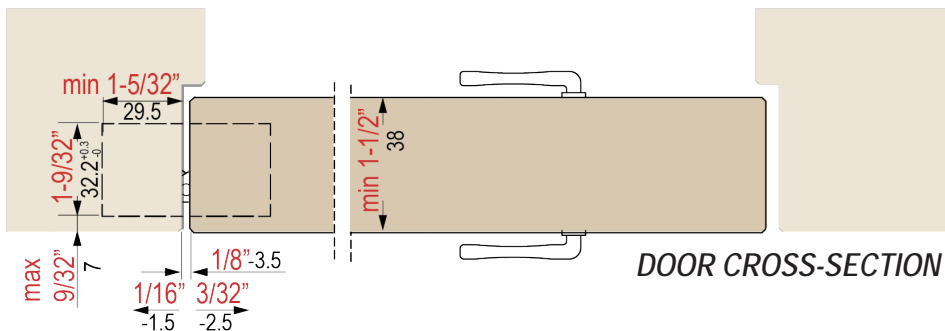
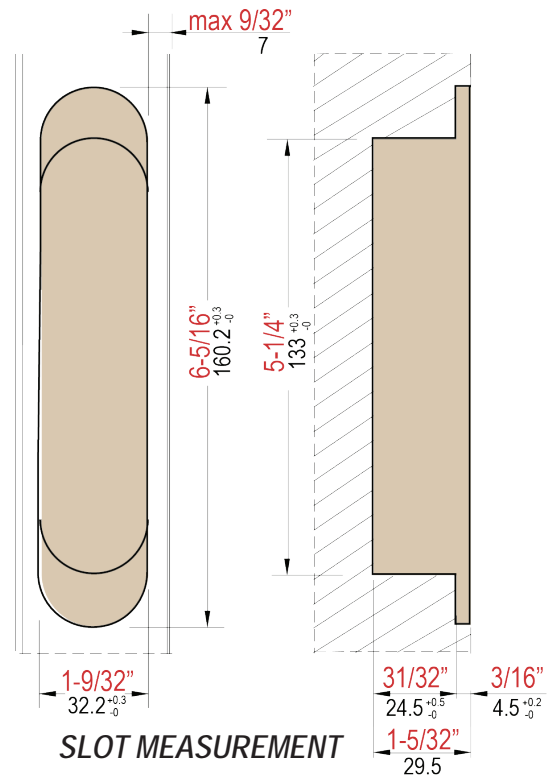
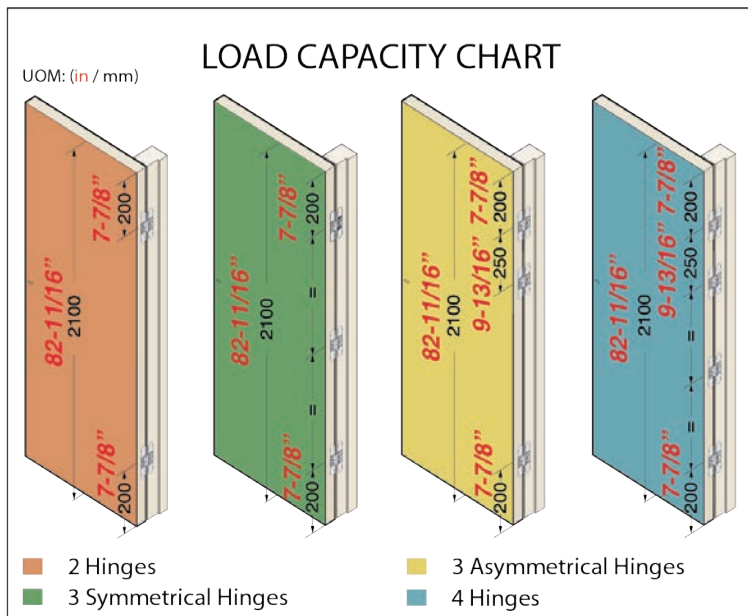
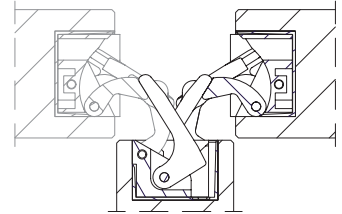

3D INVISIBLE HINGES

MAIN FEATURES

- » Zinc Alloy manufactured for Oxidation Resistance
- » Durable Galvanized Steel Covers to conceal the screws
- » Used for Wood and Hollow Metal Doors
- » **Easy 3D Adjusting System or Fixed**
- » Easy Installation and Maintenance Free
- » Complete Reversibility (same slot on the door and the frame)
- » Total Recessed Hinge Body (door and frame gap is very small)
- » **CE Certified for 200,000 Opening / Closing Cycles**
- » **100% Made in Italy**
- » Elegant Minimalistic Design that is available in **US1, US4, US10B, US14, US15, US26, US26D** and US28 finishes with no visible screws

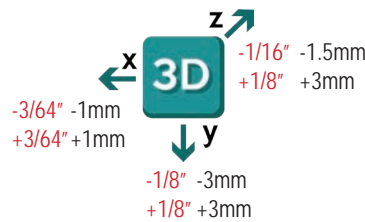

CR3D51

Dimensions: $5 \frac{1}{8}'' \times 1 \frac{3}{16}''$
(130 x 30 mm)

TECHNICAL SPECIFICATIONS:

180° Fluid Opening
$1 \frac{3}{8}''$ (35mm) minimum door thickness
Overall Length: $5 \frac{1}{8}''$ (130mm)
Width (frame part): $1 \frac{3}{16}''$ (30mm)
Width (door part): $1 \frac{3}{16}''$ (30mm)
Depth: $1 \frac{3}{16}''$ (21mm)
Load Capacity: 3 or 4 Hinges - 70kg (154lbs) 2 Hinges - 50kg (110lbs)
Fire Proof Min. : EI-30'

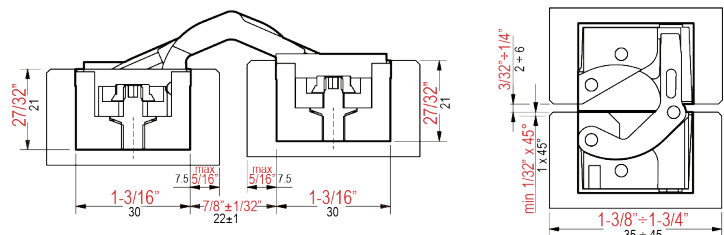
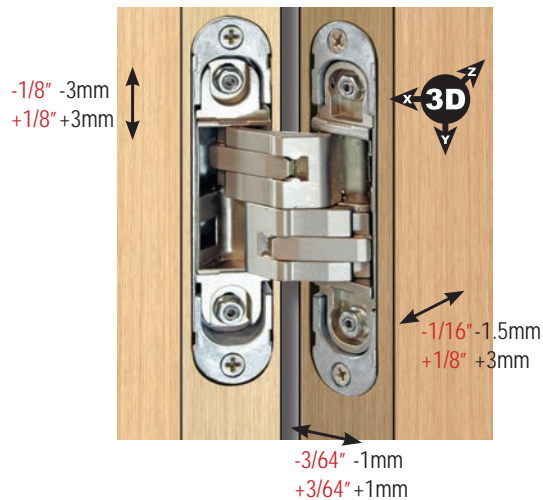
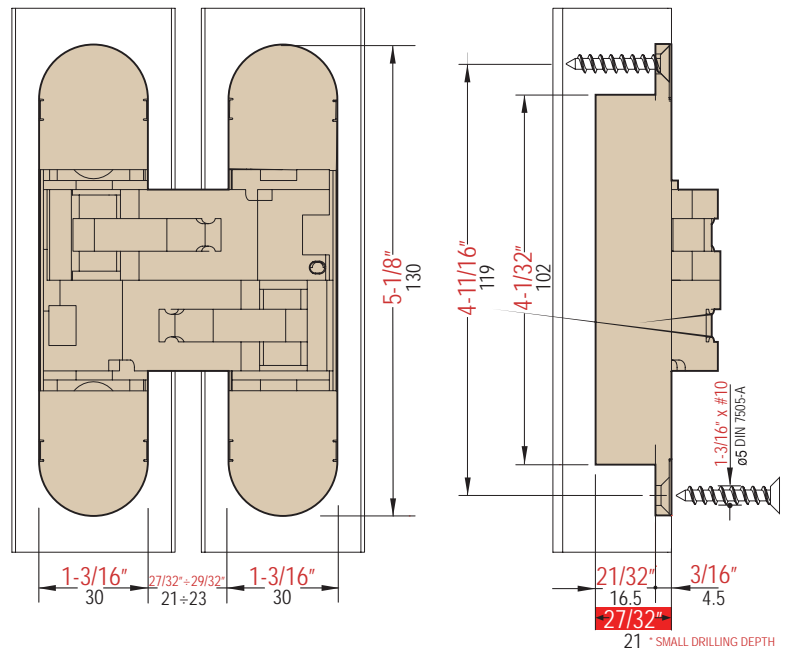

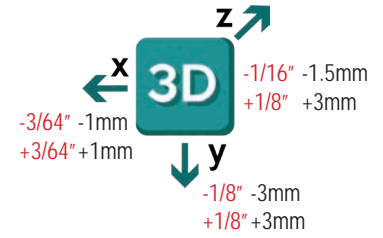
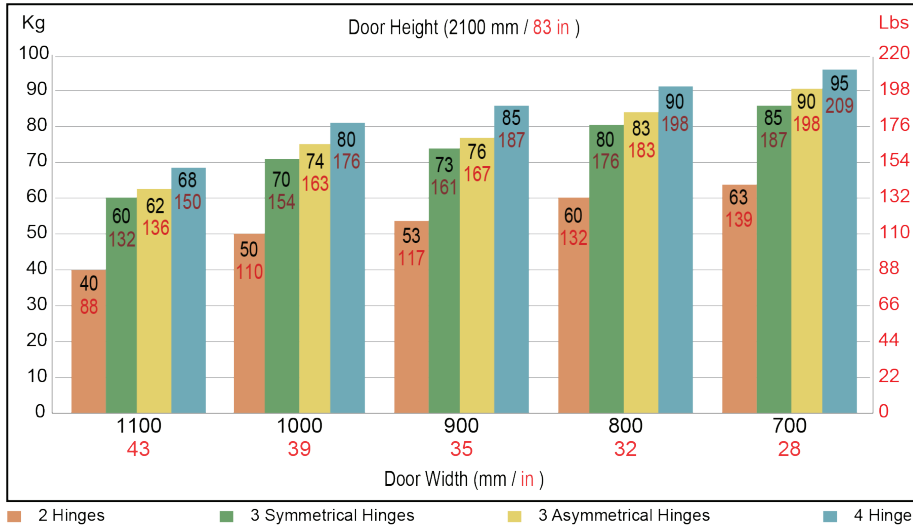

Reversible for doors from:
1 3/8" (35mm) to 1 3/4" (45mm)

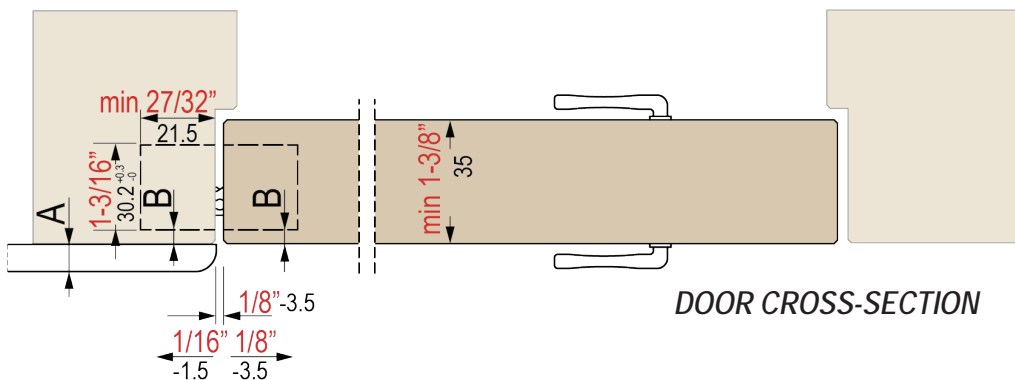
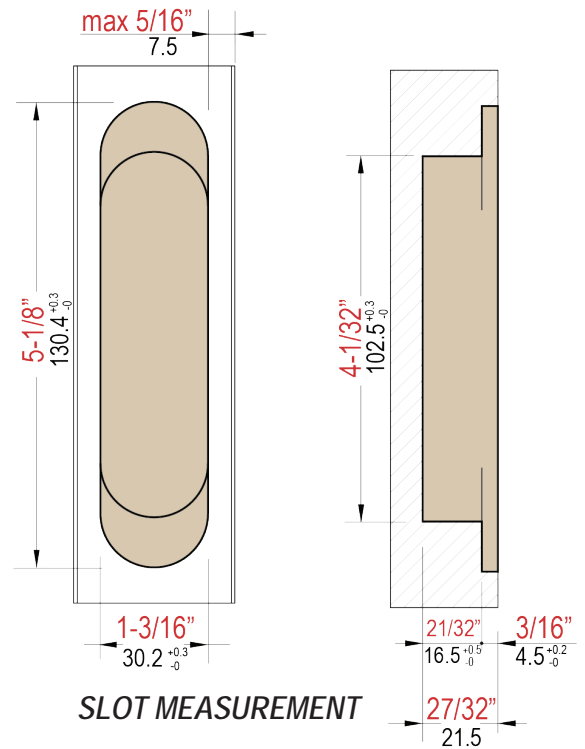
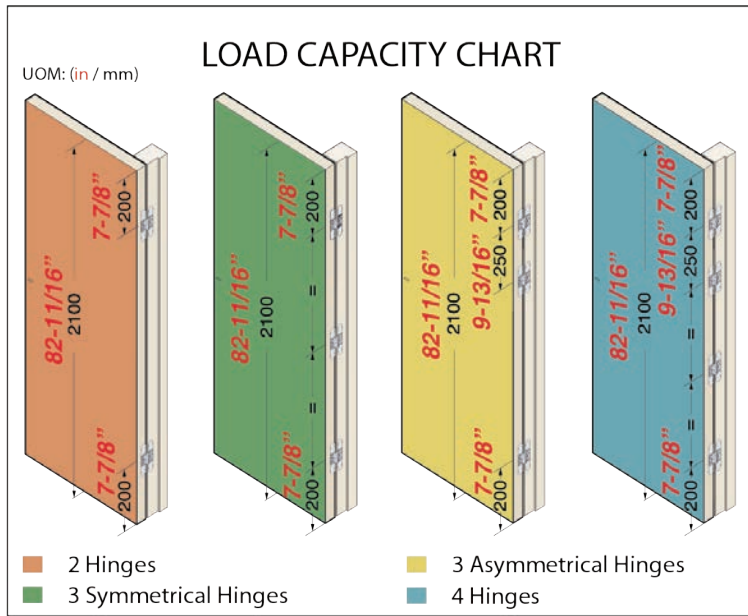
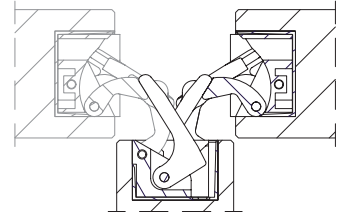

A	B
0.61" (15.5mm)	0.10" (2.5mm)
0.57" (14.5mm)	0.12" (3mm)
0.53" (13.5mm)	0.14" (3.5mm)
0.47" (12mm)	0.16" (4mm)
0.39" (10mm)	0.18" (4.5mm)
0.31" (8mm)	0.20" (5mm)

3D HINGE ACCESSORIES

3D-DT (DRILLING TEMPLATE)

- » The 3D-DT drilling template consists of a frame and two inserts, enables implementation of two slots for the invisible hinges, and is made of $\frac{3}{16}$ "(5mm) thick aluminum plates.
- » The strength of the material guarantees precise execution of the slots with a manual pantograph ($\frac{5}{8}$ " diameter cutter and 1 $\frac{1}{16}$ " external ring provided for all manual pantographs).
- » For each hinge model, two types of insertions (easily replaceable) are used: 1. To execute the butt slots
2. For the internal depth slot
- » It also comes with extension arms and nylon ring to establish the desired distance between slots on the door - both left and right - and on the frame.

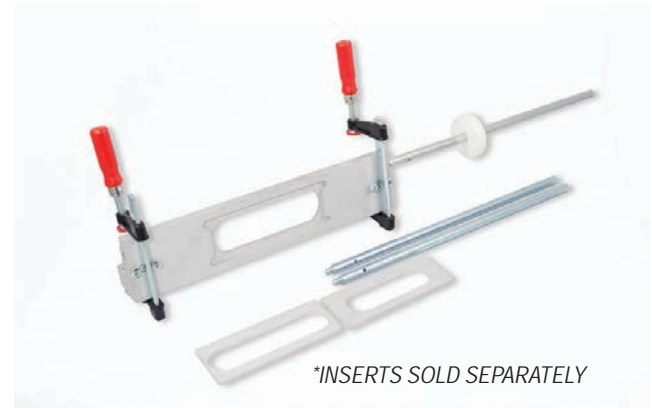

*INSERTS SOLD SEPARATELY

*Blocking Clamps

Very important for the correct use and assembly of the insert. The reference is printed on the template and the code is printed on the same side of the inserts.



1131 - for CRD62 hinge models
1230 - for CR3D51 hinge models

INSERTS FOR DRILLING TEMPLATE

- » 3D51TI - CR3D51 Inserts
- » 3D62TI - CR3D62 Inserts

NOTE: Must order inserts when ordering 3D-DT (drilling template)



3D-MTR (Metal Door Receiver)

- » Support for Steel Doors
- » Galvanized Finish
- » Installation with Welding
- » Suitable for right and left hand applications
- » 3D51-MTR - CR3D51 Metal Door Receiver
- » 3D62-MTR - CR3D62 Metal Door Receiver

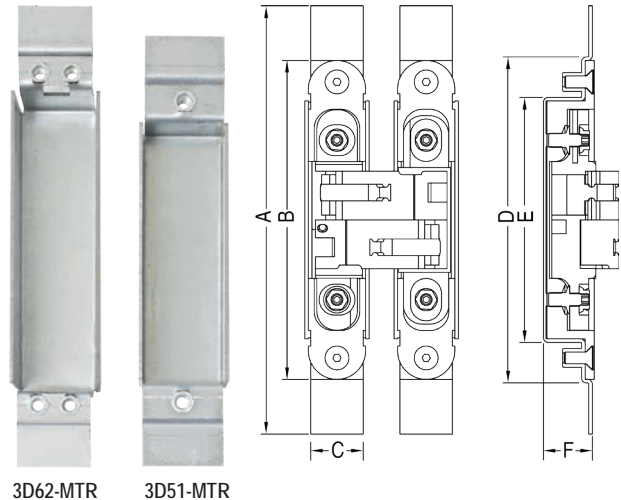
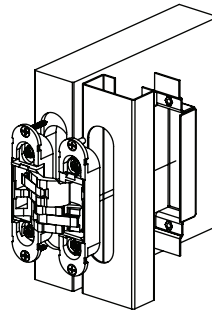

ITEM NO.	A	B	C	D	E	F
3D51-MTR	7 $\frac{3}{32}$ " 180mm	5 $\frac{1}{8}$ " 130mm	1 $\frac{1}{8}$ " 29mm	5 $\frac{1}{4}$ " 133mm	4 $\frac{1}{8}$ " 105mm	2 $\frac{7}{32}$ " 21mm
3D62-MTR	7 $\frac{13}{16}$ " 198mm	6 $\frac{11}{32}$ " 161mm	1 $\frac{3}{16}$ " 30mm	6 $\frac{15}{32}$ " 164mm	5 $\frac{1}{4}$ " 133mm	1 $\frac{7}{32}$ " 31mm

3D-ATK (ADJUSTMENT TOOL KIT)

- » Used for vertical, horizontal, and depth hinge adjustments
- » 3D51-ATK - CR3D51 Adjustment Tool Kit
- » 3D62-ATK - CR3D62 Adjustment Tool Kit

ITEM NO.	A	B
3D51-ATK	5 $\frac{1}{16}$ " (8mm)	3 $\frac{3}{32}$ " (2.5mm)
3D62-ATK	3 $\frac{3}{8}$ " (10mm)	1 $\frac{1}{8}$ " (3mm)

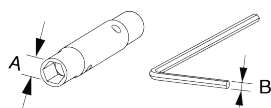

3D HINGE COVERS

- » 3D51COV - Extra Covers for CR3D51
- » 3D62COV - Extra Covers for CR3D62



3D-SCREWS

- » Extra mounting screws for CR3D51 and CR3D62 hinge models
- » Size: 1 $\frac{3}{16}$ " x #10
- » 12 pcs per bag



TECHNICAL INFORMATION for CR3D62 and CR3D51

The following parameters must be considered during the choice of the hinges, in order to prevent damage:

- Place of use and frequency of opening
- Door dimensions
- Weight of the door leaf
- Placement and installation of the hinges
- Door closer
- Coating or baseboard
- Automatic or semi-automatic opening systems

In applications like public buildings, where, due to the high opening frequencies and volume of traffic are difficult to predict, it is recommended that additional hinge be used even if the weight of the door does not require it.

All CRP hinges follow the standard regulations and passes all the necessary tests of stress, corrosion resistance, fire resistance, flow and durability. CRP tests its hinges on doors to 7'0" x 33" (2100 x 850 mm) or 7'0" x 39" (2100 x 1000 mm).

Even though the 3D hinges are maintenance-free, for an ideal performance, it is advisable to lubricate the hinge once every two years, or more, depending on the frequency of opening.

FOURTH HINGE

In some cases, the use of a fourth hinge may be decisive for the capacity, placing it in support of the upper hinge, on which act the main traction forces. In case of big widths (>35" / >900 mm) or heights (>7'0" / >2100 mm) when different forces are produced by leverage effect and center of gravity moves, the fourth hinge must be installed in the upper part of the door, because only in this position can it positively affect the weight capacity. CRP therefore advises to install 9 27/32" (250 mm) (away from the hinge at the top. In case of door height > 106 5/16" (2700mm) please contact technical department.

When using the door closer, CRP suggest mounting a fourth hinge in the upper part of the door, as these mechanisms modify the opening forces, increase the load and may alter the capacity of the hinges. In particular:

- For closers without opening force CRP suggest considering **20% more of the real door weight**.
- For closers with opening force the effect is much greater; it is estimated that the leaf effective mass is **75% bigger of the actual one**.

NOTES

The information herewith reported are indicative guidelines. In practice, the variables that affect the correct functioning of the hinge are several: according to the nature of the door, transit and employment, it can certainly be reasonable to analyze every single application. The customer must be sure hinges' proportions are enough to satisfy even external factors beyond what is indicated by tests. If necessary, please contact our technical department.

ADJUSTMENT IN 3 DIMENSIONS

Every adjustment requires adequate attention. The adjustment range indicated must be absolutely followed. Excessive force during adjustments can lead to a possible malfunction that could cause system failure.

ZERO POSITION

All CRP 3D hinges are delivered with all the adjustments centered.
After installation and after each adjustment all components must be tightened firmly.

ADJUSTMENT ON THE THREE INDEPENDENT AXES

Horizontal from $-1/16"$ to $+1/8"$ (see individual specifications)
Vertical from $-1/8"$ to $+1/8"$ (see individual specifications)
Depth $+/- 3/64"$

HORIZONTAL ADJUSTMENT

Slightly loosen the locking nuts.
With the aid of the Allen key, move the internal cage to find the preferred position.
Tighten all lock nuts.

VERTICAL ADJUSTMENT

Slightly loosen the locking nuts.
By acting on the door leaf, raise it to the required level.
Tighten all lock nuts.

DEPTH ADJUSTMENT

Slightly loosen the locking nuts.
Act with hexagonal Allen key to make the adjustment.
Tighten all lock nuts.
All adjustments are carried out with 5/16" hex wrench and Allen key 3/32" (for CR3D62 hinge, to be made with a hexagonal 3/8" and 1/8" Allen key).

