

# 3D INVISIBLE HINGES

*100% Made in Italy*



# 3D INVISIBLE HINGES

## MAIN FEATURES

- » Zinc Alloy manufactured for Oxidation Resistance
- » Durable Galvanized Steel Covers to conceal the screws
- » Used for Wood and Hollow Metal Doors
- » **Easy 3D Adjusting System**
- » Easy Installation and Maintenance Free
- » Complete Reversibility (same slot on the door and the frame)
- » Total Recessed Hinge Body (door and frame gap is very small)
- » Milling cut up to 1/4" (6.5mm) from the internal edge
- » **European Standard EN1634-1 for 90-Minute Fire Doors**
- » **CE Certified for 200,000 Opening / Closing Cycles**
- » **100% Made in Italy**
- » Elegant Minimalistic Design that is available in **US1, US10B, US15, and US28** finishes with no visible screws



EN 1634-1  
EI-90

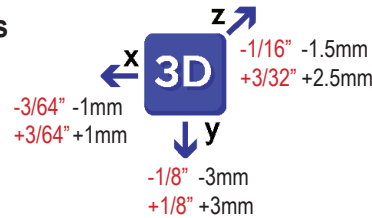

## CR3D44

Dimensions:  $7 \frac{3}{32}'' \times 1 \frac{1}{4}''$   
(180 x 32 mm)

## TECHNICAL SPECIFICATIONS:

180° Fluid Opening
1 1/2" (38mm) minimum door thickness
Overall Length: $7 \frac{3}{32}''$ (180mm)
Width (frame part): $1 \frac{1}{4}''$ (32mm)
Width (door part): $1 \frac{1}{4}''$ (32mm)
Depth: $1 \frac{1}{8}''$ (29mm)
<b>Load Capacity: 3 or 4 Hinges - 135kg (298lbs)</b> <b>2 Hinges - 120kg (265lbs)</b>
Fire Proof Min. : EI-90'

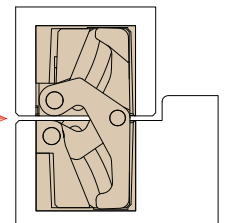
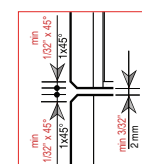
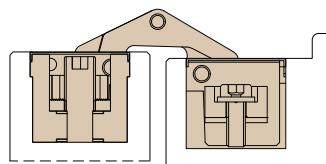
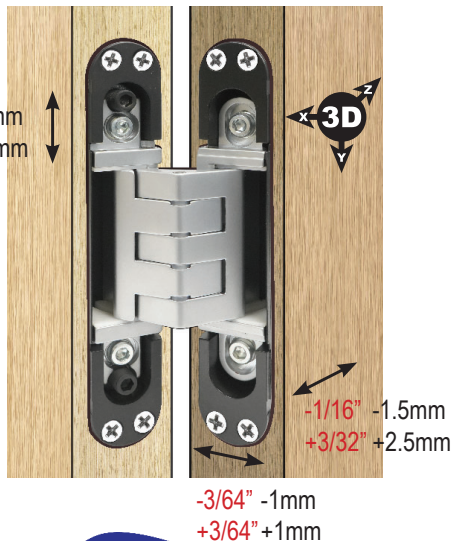
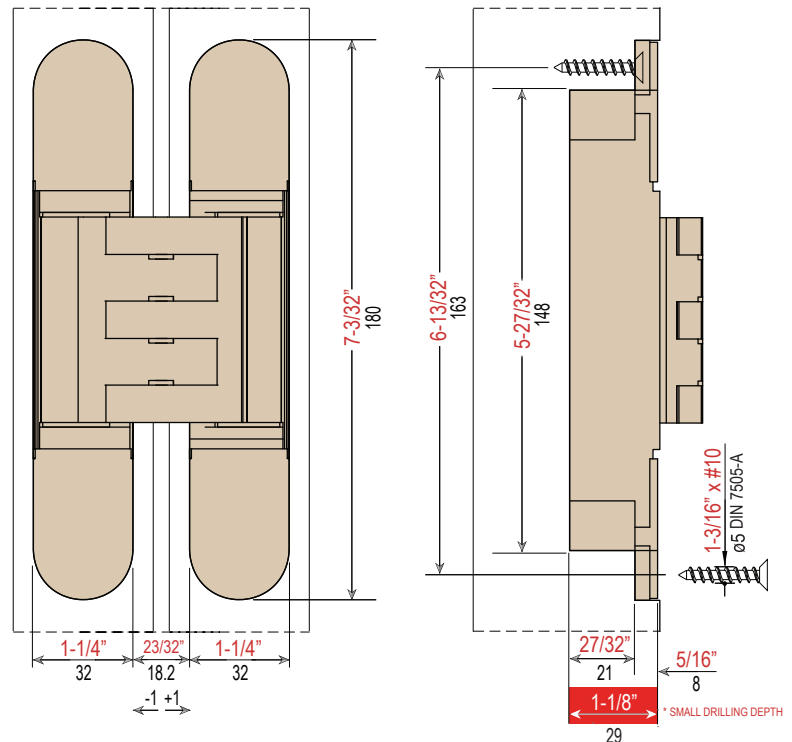

**2 HINGES LOAD CAPACITY CHART (kg / lbs)**

<b>DOOR HEIGHT (mm / in)</b>	2200 86 5/8"	120 265	120 265	120 265	118 260	100 220	89 196	81 179
	2100 82 11/16"	120 265	120 265	120 265	108 238	94 207	84 185	78 172
	2000 78 3/4"	120 265	120 265	120 265	100 220	88 194	80 176	74 163
	1900 74 13/16"	120 265	120 265	109 240	93 205	83 183	76 168	71 157
		700 27 9/16"	800 31 1/2"	900 35 7/16"	1000 39 3/8"	1100 43 5/16"	1200 47 1/4"	1300 51 3/16"
<b>DOOR WIDTH (mm / in)</b>								

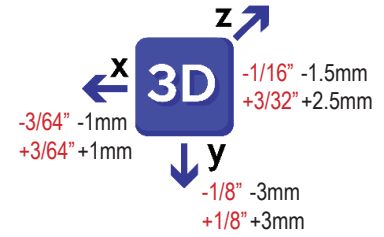

Reversible for doors from:  
1 1/2" (38mm) to 1 25/32" (45mm)

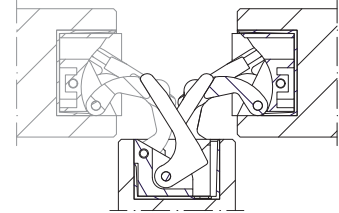

**3 HINGES LOAD CAPACITY CHART (kg / lbs)**

<b>DOOR HEIGHT (mm / in)</b>	3000 118 1/8"	135 265	135 265	135 265	135 265	135 265	135 265	135 265	<b>4 HINGES SUGGESTED</b>
	2900 114 5/32"	135 265	135 265	135 265	135 265	135 265	135 265	135 265	
	2800 110 1/4"	135 265	135 265	135 265	135 265	135 265	135 265	126 278	
	2700 106 5/16"	135 265	135 265	135 265	135 265	135 265	135 265	118 260	
	2600 102 3/8"	135 265	135 265	135 265	135 265	135 265	128 282	110 243	
	2500 98 7/16"	135 265	135 265	135 265	135 265	135 265	119 262	104 229	
	2400 94 1/2"	135 265	135 265	135 265	135 265	130 287	110 243	98 216	
	2300 90 9/16"	135 265	135 265	135 265	135 265	119 262	103 227	93 205	
	2200 86 5/8"	135 265	135 265	135 265	132 291	110 243	97 214	88 194	
	2100 82 11/16"	135 265	135 265	135 265	120 265	103 227	92 203	84 185	
	2000 78 3/4"	135 265	135 265	135 265	110 243	96 212	87 192	80 176	
		700 27 9/16"	800 31 1/2"	900 35 7/16"	1000 39 3/8"	1100 43 5/16"	1200 47 1/4"	1300 51 3/16"	
<b>DOOR WIDTH (mm / in)</b>									

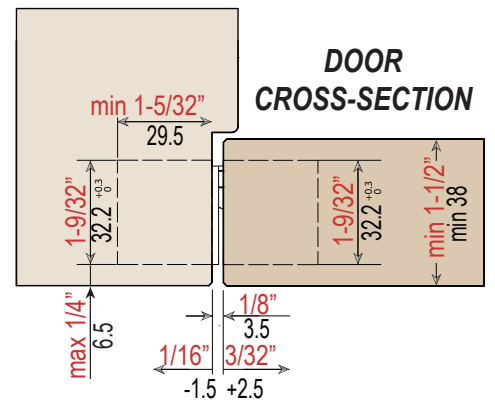
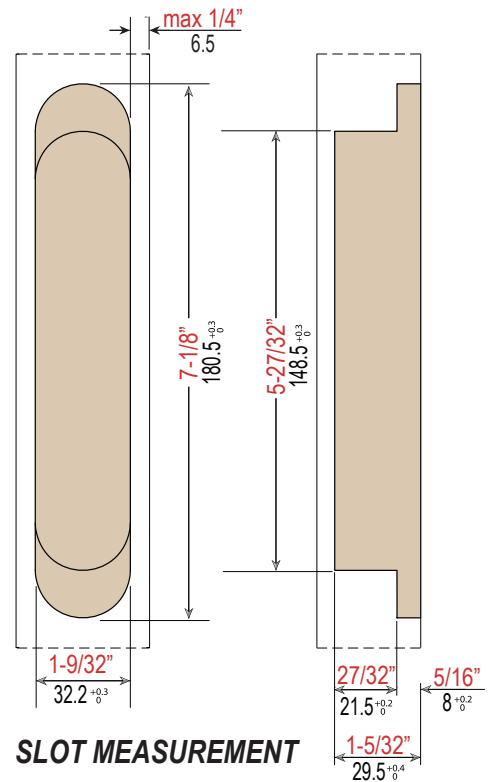



**3D INVISIBLE HINGES**

**MAIN FEATURES**

- » Zinc Alloy manufactured for Oxidation Resistance
- » Durable Galvanized Steel Covers to conceal the screws
- » Used for Wood and Hollow Metal Doors
- » **Easy 3D Adjusting System**
- » Easy Installation and Maintenance Free
- » Complete Reversibility (same slot on the door and the frame)
- » Total Recessed Hinge Body (door and frame gap is very small)
- » Internal milling up to 3/8" (10mm) from the edge
- » **European Standard EN1634-1 for 60-Minute Fire Doors**
- » **CE Certified for 200,000 Opening / Closing Cycles**
- » **100% Made in Italy**
- » Elegant minimalistic design that is available in **US1, US4, US10B, US14, US15, US26, US26D** and **US28** finishes with no visible screws



EN 1634-1  
EI-60

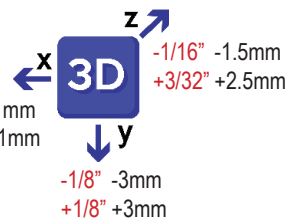

**CR3D81**

Dimensions: 5 1/8" x 1 3/16"  
(130 x 30 mm)

**TECHNICAL SPECIFICATIONS:**

180° Fluid Opening
1 3/8" to 2" (35 to 50mm) door thickness
Overall Length: 5 1/8" (130mm)
Width (frame part): 1 3/16" (30mm)
Width (door part): 1 3/16" (30mm)
Depth: 13/16" (21mm) & 1 5/16" (33mm)
Load Capacity: 3 or 4 Hinges - 80kg (176lbs) 2 Hinges - 60kg (132lbs)
Fire Proof Min. : EI-60'

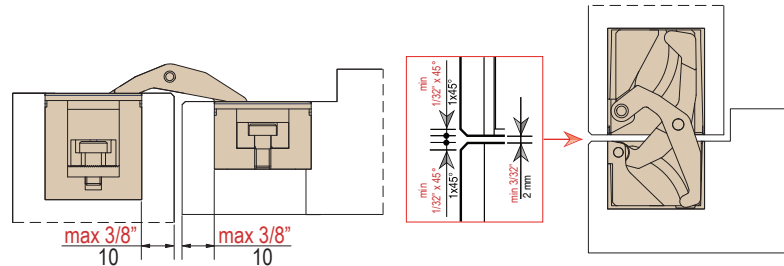
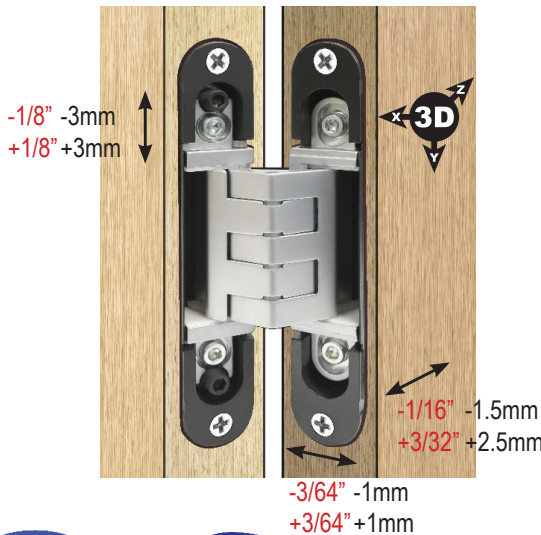
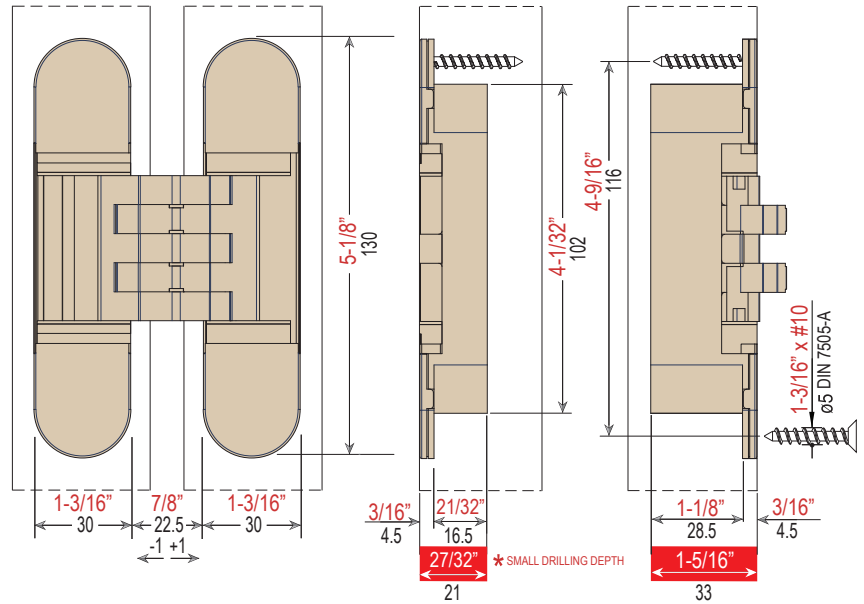

**2 HINGES LOAD CAPACITY CHART (kg / lbs)**

DOOR HEIGHT (mm / in)	2200 86 5/8"	60 132	60 132	60 132	59 130	51 112	46 101	42 93
	2100 82 11/16"	60 132	60 132	60 132	55 121	48 106	44 97	40 88
	2000 78 3/4"	60 132	60 132	60 132	51 112	46 101	42 93	39 86
	1900 74 13/16"	60 132	60 132	55 121	48 106	43 95	40 88	38 84

700 27 9/16"	800 31 1/2"	900 35 7/16"	1000 39 3/8"	1100 43 5/16"	1200 47 1/4"	1300 51 3/16"
DOOR WIDTH (mm / in)						

**3 HINGES LOAD CAPACITY CHART (kg / lbs)**

DOOR HEIGHT (mm / in)	3000 118 1/8"	80 176	80 176	80 176	80 176	80 176	80 176	80 176	4 HINGES SUGGESTED
	2900 114 5/32"	80 176	80 176	80 176	80 176	80 176	80 176	80 176	
	2800 110 1/4"	80 176	80 176	80 176	80 176	80 176	80 176	75 165	
	2700 106 5/16"	80 176	80 176	80 176	80 176	80 176	80 176	71 157	
	2600 102 3/8"	80 176	80 176	80 176	80 176	80 176	76 168	67 148	
	2500 98 7/16"	80 176	80 176	80 176	80 176	80 176	71 157	64 141	
	2400 94 1/2"	80 176	80 176	80 176	80 176	77 170	67 148	61 134	
	2300 90 9/16"	80 176	80 176	80 176	80 176	72 159	64 141	58 128	
	2200 86 3/8"	80 176	80 176	80 176	78 172	67 148	60 132	56 123	
	2100 82 11/16"	80 176	80 176	80 176	72 159	63 139	57 126	54 119	
	2000 78 3/4"	80 176	80 176	80 176	67 148	60 132	55 121	52 115	

700 27 9/16"	800 31 1/2"	900 35 7/16"	1000 39 3/8"	1100 43 5/16"	1200 47 1/4"	1300 51 3/16"
DOOR WIDTH (mm / in)						

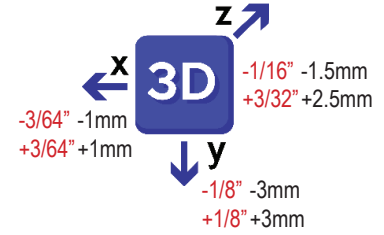

Reversible for doors from:  
1 3/8" (35mm) to 2" (50mm)

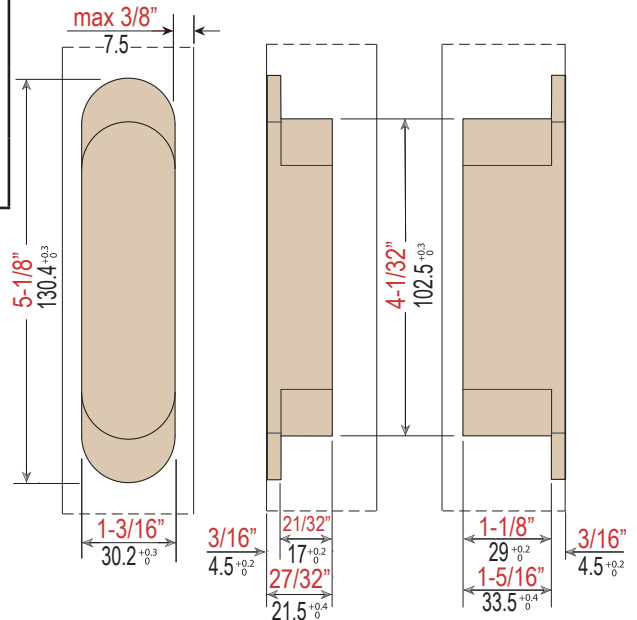
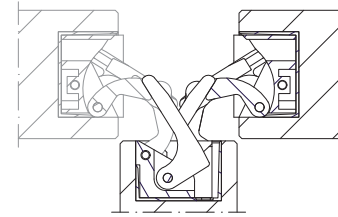

**SLOT MEASUREMENT**

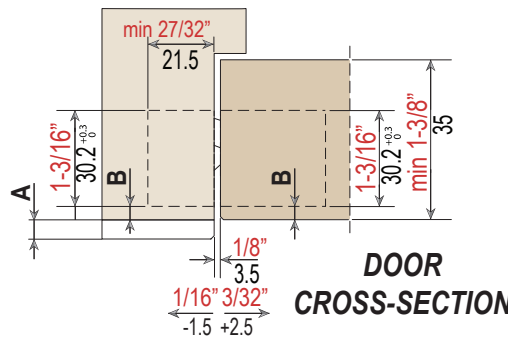

**DOOR CROSS-SECTION**

A	B
0.61" (15.5mm)	0.10" (2.5mm)
0.57" (14.5mm)	0.12" (3mm)
0.53" (13.5mm)	0.14" (3.5mm)
0.49" (12.5mm)	0.16" (4mm)
0.45" (11.5mm)	0.18" (4.5mm)
0.41" (10.5mm)	0.20" (5mm)
0.37" (9.5mm)	0.22" (5.5mm)

# 3D INVISIBLE HINGES

## MAIN FEATURES

- » Zinc Alloy manufactured for Oxidation Resistance
- » Durable Galvanized Steel Covers to conceal the screws
- » Used for Wood and Hollow Metal Doors
- » **Easy 3D Adjusting System**
- » Easy Installation and Maintenance Free
- » Complete Reversibility (same slot on the door and the frame)
- » Total Recessed Hinge Body (door and frame gap is very small)
- » Milling cut up to  $\frac{9}{32}$ " (7mm) from the internal edge
- » **UL Listed for 2-Hour Fire Rated Doors**

**(UL LISTING APPLICABLE ONLY FOR USE ON WOOD / COMPOSITE TYPE DOORS)**

- » **European Standard EN1634-1 for 120-Minute Fire Doors**
- » **CE Certified for 200,000 Opening / Closing Cycles**
- » **100% Made in Italy**
- » Elegant Minimalistic Design that is available in **US1, US4, US10B, US14, US15, US26, US26D** and **US28** finishes with no visible screws



## CR3D62

Dimensions:  $6 \frac{5}{16}$ " x  $1 \frac{1}{4}$ "  
(160 x 32 mm)

## TECHNICAL SPECIFICATIONS:

- 180° Fluid Opening
- $1 \frac{1}{2}$ " (38mm) minimum door thickness
- Overall Length:  $6 \frac{5}{16}$ " (160mm)
- Width (frame part):  $1 \frac{1}{4}$ " (32mm)
- Width (door part):  $1 \frac{1}{4}$ " (32mm)
- Depth:  $1 \frac{1}{8}$ " (29mm)
- Load Capacity: 3 or 4 Hinges - 120kg (265lbs)  
2 Hinges - 80kg (177lbs)
- Fire Proof Min. : EI-120'

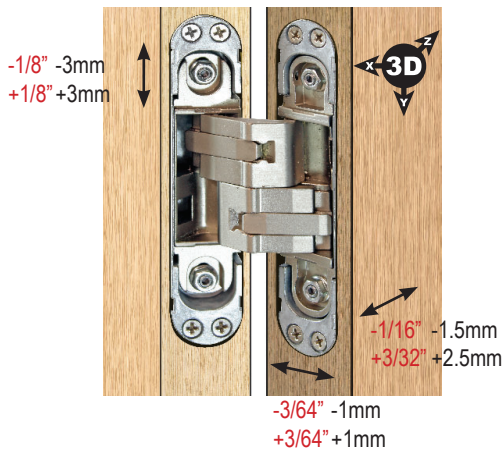
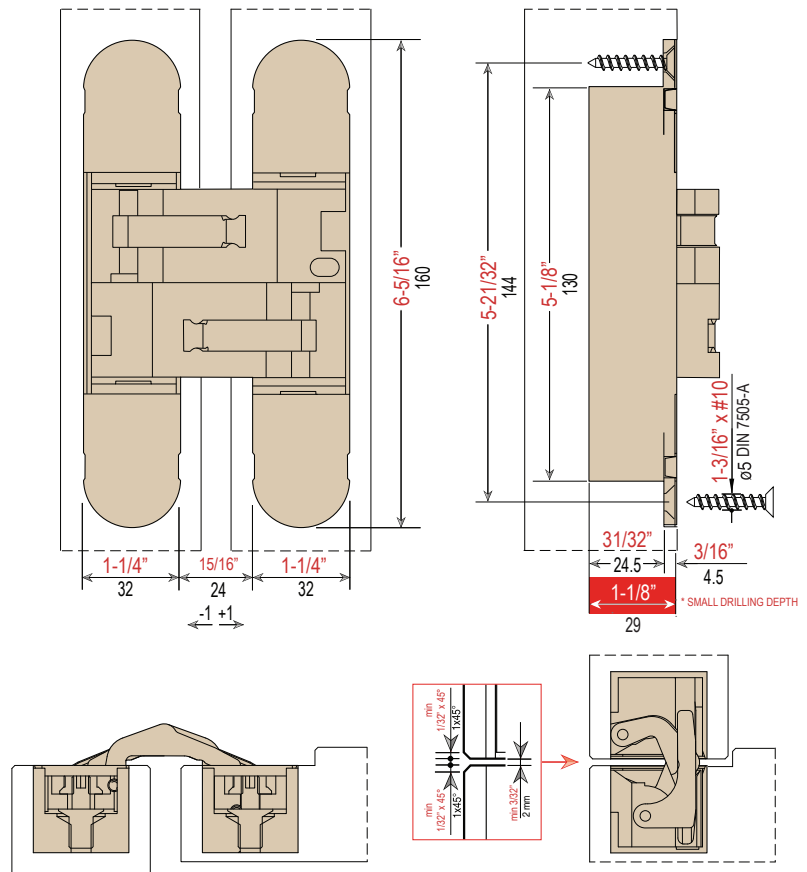
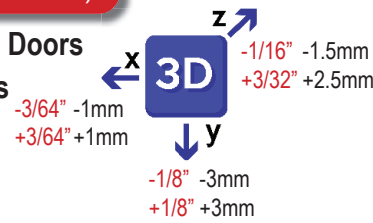

		<b>2 HINGES LOAD CAPACITY CHART (kg / lbs)</b>						
<b>DOOR HEIGHT (mm / in)</b>	2200 86 5/8"	80 176	80 176	80 176	78 172	66 146	59 130	54 119
	2100 82 11/16"	80 176	80 176	80 176	72 159	62 137	56 123	52 115
	2000 78 3/4"	80 176	80 176	80 176	66 146	58 128	53 117	49 108
	1900 74 13/16"	80 176	80 176	73 161	62 137	55 121	51 112	47 104
		700 27 9/16"	800 31 1/2"	900 35 7/16"	1000 39 3/8"	1100 43 5/16"	1200 47 1/4"	1300 51 3/16"
		<b>DOOR WIDTH (mm / in)</b>						

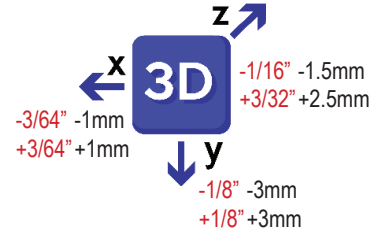

Reversible for doors from:  
1 1/2" (38mm) to 1 13/16" (46mm)

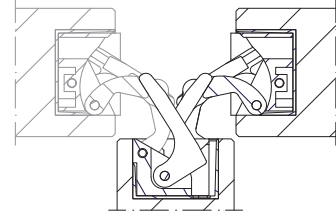

		<b>3 HINGES LOAD CAPACITY CHART (kg / lbs)</b>							<b>4 HINGES SUGGESTED</b>
<b>DOOR HEIGHT (mm / in)</b>	3000 118 1/8"	120 265	120 265	120 265	120 265	120 265	120 265	120 265	
	2900 114 5/32"	120 265	120 265	120 265	120 265	120 265	120 265	120 265	
	2800 110 1/4"	120 265	120 265	120 265	120 265	120 265	120 265	112 247	
	2700 106 5/16"	120 265	120 265	120 265	120 265	120 265	120 265	105 231	
	2600 102 3/8"	120 265	120 265	120 265	120 265	120 265	114 251	98 216	
	2500 98 7/16"	120 265	120 265	120 265	120 265	120 265	105 231	92 203	
	2400 94 1/2"	120 265	120 265	120 265	120 265	115 254	98 216	87 192	
	2300 90 9/16"	120 265	120 265	120 265	120 265	106 234	92 203	83 183	
	2200 86 5/8"	120 265	120 265	120 265	117 258	98 216	86 190	78 172	
	2100 82 11/16"	120 265	120 265	120 265	107 236	91 201	82 181	75 165	
	2000 78 3/4"	120 265	120 265	120 265	98 216	85 187	77 170	71 157	
		700 27 9/16"	800 31 1/2"	900 35 7/16"	1000 39 3/8"	1100 43 5/16"	1200 47 1/4"	1300 51 3/16"	
		<b>DOOR WIDTH (mm / in)</b>							

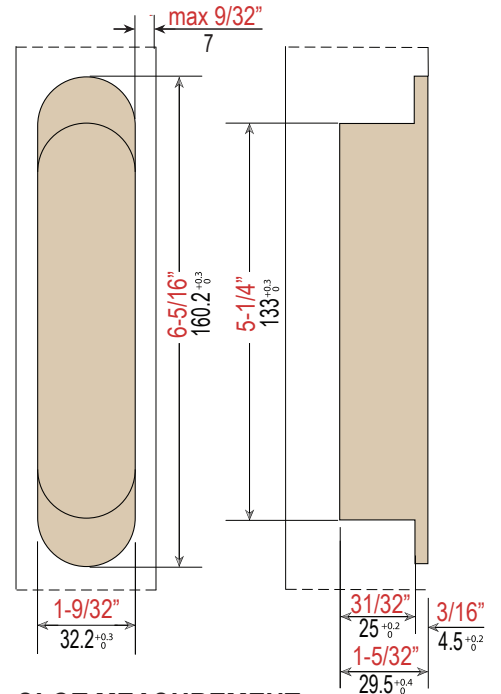

**SLOT MEASUREMENT**

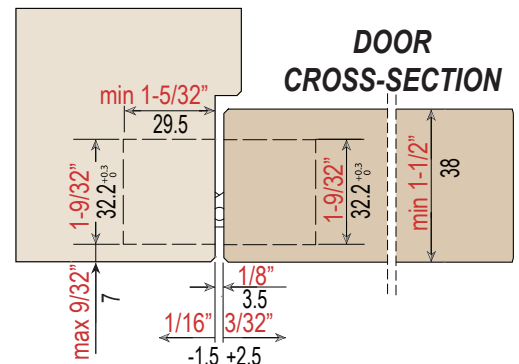

**DOOR CROSS-SECTION**



# 3D INVISIBLE HINGES

## MAIN FEATURES

- » Zinc Alloy manufactured for Oxidation Resistance
- » Durable Galvanized Steel Covers to conceal the screws
- » Used for Wood and Hollow Metal Doors
- » **Easy 3D Adjusting System**
- » Easy Installation and Maintenance Free
- » Complete Reversibility (same slot on the door and the frame)
- » Total Recessed Hinge Body (door and frame gap is very small)
- » Milling cut up to 1/4" (7.5mm) from the internal edge
- » **European Standard EN1634-2 for 30-Minute Fire Doors**
- » **CE Certified for 200,000 Opening / Closing Cycles**
- » **100% Made in Italy**
- » Elegant Minimalistic Design that is available in **US1, US4, US10B, US14, US15, US26, US26D and US28** finishes with no visible screws

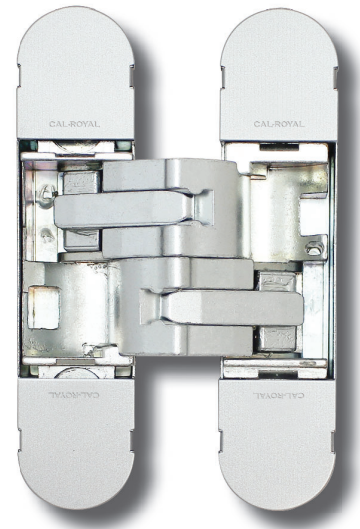

## CR3D51

Dimensions: 5 1/8" x 1 3/16"  
(130 x 30 mm)

## TECHNICAL SPECIFICATIONS:

180° Fluid Opening
1 3/8" (35mm) minimum door thickness
Overall Length: 5 1/8" (130mm)
Width (frame part): 1 3/16" (30mm)
Width (door part): 1 3/16" (30mm)
Depth: 13/16" (21mm)
Load Capacity: 3 or 4 Hinges - 70kg (154lbs) 2 Hinges - 55kg (121lbs)
Fire Proof Min. : EI-30'

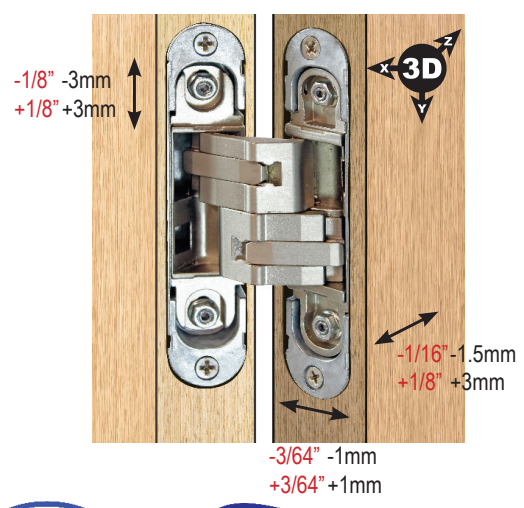
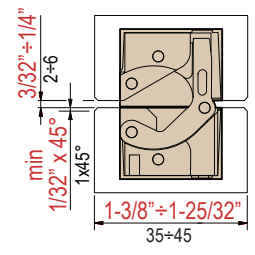
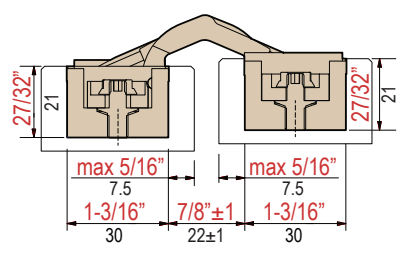
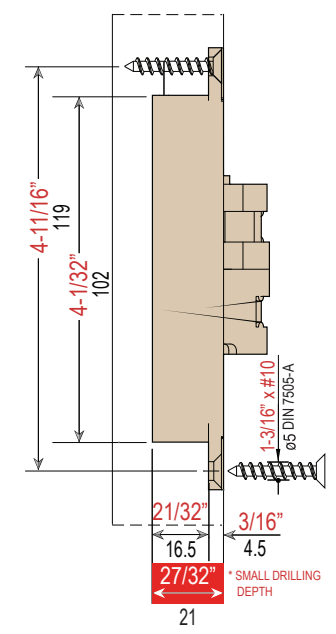
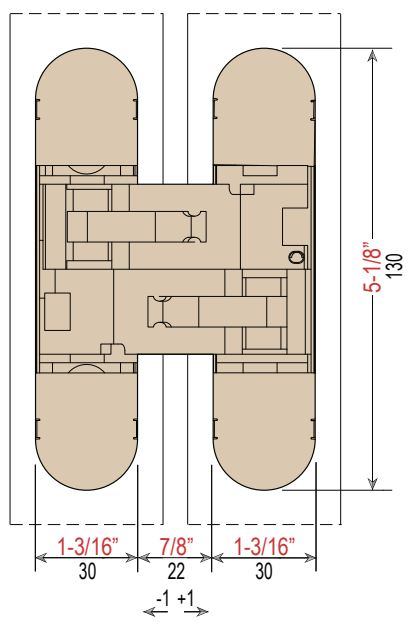
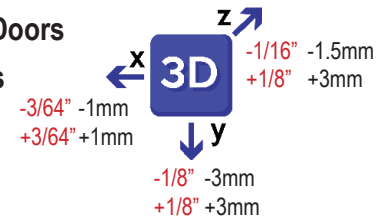



**2 HINGES LOAD CAPACITY CHART (kg / lbs)**

<b>DOOR HEIGHT (mm / in)</b>	2200 86 5/8"	55 121	55 121	55 121	54 119	46 101	41 90	37 82
	2100 82 11/16"	55 121	55 121	55 121	50 110	43 95	39 86	36 79
	2000 78 3/4"	55 121	55 121	55 121	46 101	41 90	37 82	34 75
	1900 74 13/16"	55 121	55 121	50 110	43 95	38 84	35 77	33 73

700 27 9/16"	800 31 1/2"	900 35 7/16"	1000 39 3/8"	1100 43 5/16"	1200 47 1/4"	1300 51 3/16"
<b>DOOR WIDTH (mm / in)</b>						

**3 HINGES LOAD CAPACITY CHART (kg / lbs)**

<b>DOOR HEIGHT (mm / in)</b>	3000 118 1/8"	70 154	70 154	70 154	70 154	70 154	70 154	70 154	<b>4 HINGES SUGGESTED</b>
	2900 114 5/32"	70 154	70 154	70 154	70 154	70 154	70 154	70 154	
	2800 110 1/4"	70 154	70 154	70 154	70 154	70 154	70 154	65 143	
	2700 106 5/16"	70 154	70 154	70 154	70 154	70 154	70 154	61 134	
	2600 102 5/8"	70 154	70 154	70 154	70 154	70 154	66 146	57 126	
	2500 98 7/16"	70 154	70 154	70 154	70 154	70 154	61 134	54 119	
	2400 94 1/2"	70 154	70 154	70 154	70 154	67 148	57 126	51 112	
	2300 90 9/16"	70 154	70 154	70 154	70 154	62 132	54 119	48 106	
	2200 86 5/8"	70 154	70 154	70 154	68 150	57 126	50 110	46 101	
	2100 82 11/16"	70 154	70 154	70 154	62 137	53 117	47 104	44 97	
	2000 78 3/4"	70 154	70 154	70 154	57 126	50 110	45 99	42 93	

700 27 9/16"	800 31 1/2"	900 35 7/16"	1000 39 3/8"	1100 43 5/16"	1200 47 1/4"	1300 51 3/16"
<b>DOOR WIDTH (mm / in)</b>						

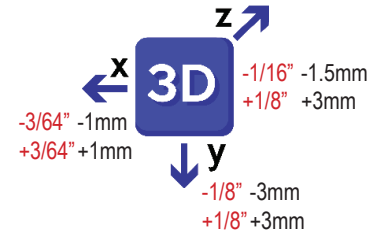

Reversible for doors from:  
1 3/8" (35mm) to 1 3/4" (45mm)

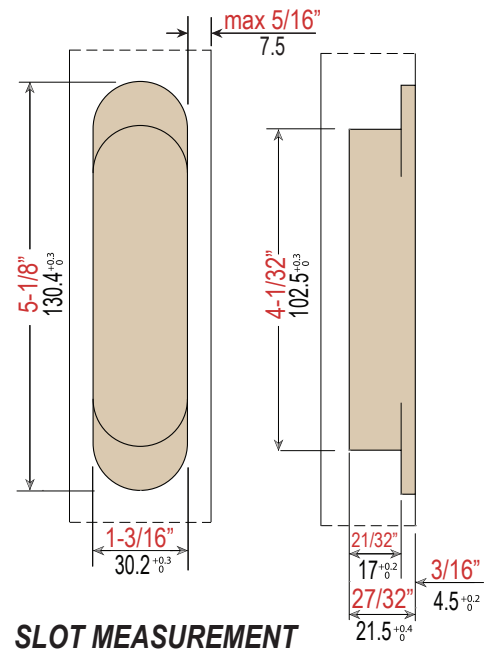
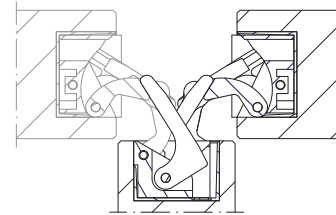

**SLOT MEASUREMENT**

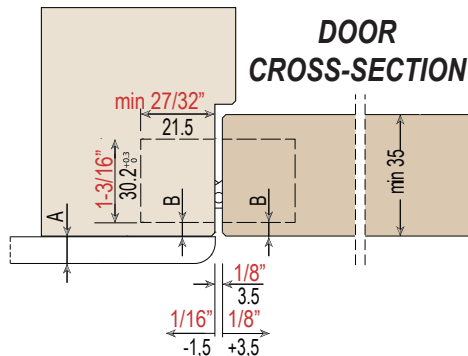

A	B
0.61" (15.5mm)	0.10" (2.5mm)
0.57" (14.5mm)	0.12" (3mm)
0.53" (13.5mm)	0.14" (3.5mm)
0.47" (12mm)	0.16" (4mm)
0.39" (10mm)	0.18" (4.5mm)
0.31" (8mm)	0.20" (5mm)

**3D HINGE ACCESSORIES**

**Drilling Template - 3D-DT (for CR3D62, CR3D51, CR3D81), 3D-DT2 (for CR3D44)**

- » The drilling template consists of a frame and two inserts, enables implementation of two slots for the invisible hinges, and is made of 3/16" (5mm) thick aluminum plates.
- » The strength of the material guarantees precise execution of the slots with a manual pantograph (5/8" diameter cutter and 1 1/16" external ring provided for all manual pantographs).
- » For each hinge model, **two types of insertions** (easily replaceable) are used:
  1. To execute the butt slots, 2. For the internal depth slot
- » It also comes with extension arms and nylon ring to establish the desired distance between slots on the door - both left and right - and on the frame.

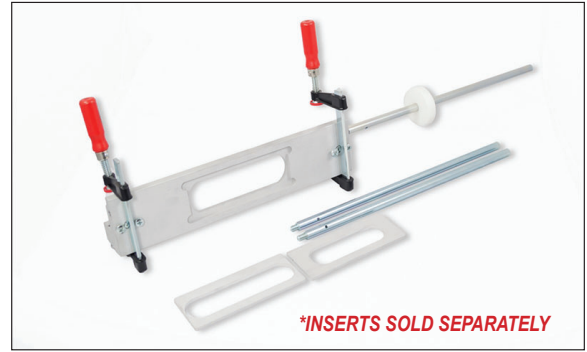

**\*INSERTS SOLD SEPARATELY**

**\*Blocking Clamps**

*Very important for the correct use and assembly of the insert. The reference is printed on the template and the code is printed on the same side of the inserts.*

- 1131 - for CRD62 hinge models
- 1230 - for CR3D51 & CR3D81 hinge models
- 1431 - for CR3D44 hinge models

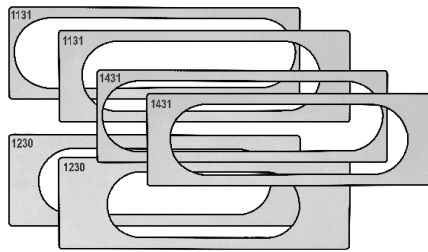

**INSERTS FOR DRILLING TEMPLATE**

- » 3D-51TI - CR3D51 & CR3D81 Inserts
- » 3D-62TI - CR3D62 Inserts
- » 3D-44TI - CR3D44 Inserts

**NOTE: Must order inserts when ordering drilling template**

**Metal Door Receiver**

- » Support for Steel Doors
- » Galvanized Finish
- » Installation with Welding
- » Suitable for right and left hand applications
- » **3D51-MTR** - CR3D51 Metal Door Receiver
- » **3D62-MTR** - CR3D62 Metal Door Receiver
- » **3D44-MTR** - CR3D44 Metal Door Receiver
- » **3D81-MTR** - CR3D81 Metal Door Receiver

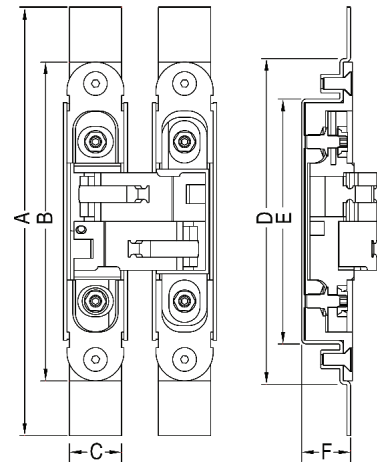
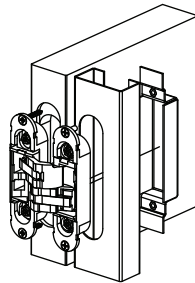

**NOTE: Must order machine screws when ordering Metal Door Receiver**

**3D-MSCREWS**

- » Machine screws
- » Size: 10-32 x 3/4", #9



**3D-SCREWS**

- » Extra mounting screws
- » Size: 1 3/16" x #10
- » 12 pcs per bag



**3D HINGE COVERS**

- » **3D51COV** - Extra Covers for CR3D51
- » **3D62COV** - Extra Covers for CR3D62
- » **3D44COV** - Extra Covers for CR3D62
- » **3D81COV** - Extra Covers for CR3D81



**Adjustment Tool Kit**

- » Used for vertical, horizontal, and depth hinge adjustments
- » **3D51-ATK** - CR3D51 Adjustment Tool Kit
- » **3D62-ATK** - CR3D62 Adjustment Tool Kit
- » **3D44-ATK** - CR3D44 Adjustment Tool Kit
- » **3D81-ATK** - CR3D81 Adjustment Tool Kit



ITEM NO.	A	B
3D51-ATK	5/16" (8mm)	3/32" (2.5mm)
3D62-ATK	3/8" (10mm)	1/8" (3mm)
3D44-ATK	N/A	3/16" (5mm)
3D81-ATK	N/A	5/32" (4mm)

ITEM NO.	A	B	C	D	E	F
3D51-MTR	7 3/32"	5 1/8"	1 1/8"	5 1/4"	4 1/8"	27/32"
	180mm	130mm	29mm	133mm	105mm	21mm
3D62-MTR	7 13/16"	6 11/32"	1 3/16"	6 15/32"	5 1/4"	1 7/32"
	198mm	161mm	30mm	164mm	133mm	31mm
3D44-MTR	9 1/16"	7 3/16"	1 3/16"	7 5/16"	5 7/8"	1 5/32"
	230mm	182mm	30.5mm	185mm	149mm	29.5mm
3D81-MTR	7 3/32"	5 1/8"	1 1/8"	5 3/16"	4 3/16"	1 5/16"
	180mm	130mm	29mm	132mm	106.5mm	33.5mm

**TECHNICAL INFORMATION for CR3D62, CR3D51, CR3D44, CR3D81**

The following parameters must be considered during the choice of the hinges, in order to prevent damage:

- Place of use and frequency of opening
- Door dimensions
- Weight of the door leaf
- Placement and installation of the hinges
- Door closer and other accessories
- Automatic or semi-automatic opening systems

In particular, hinges are increasingly stressed:

- By increasing door weight
- By decreasing height/width ratio or, simplifying, by increasing of the door width in relation to the door height.

In the catalog and instruction sheets, you can find the load capacity chart for every single product.

These charts give clear orientations to the end user to determine the right model, the proper combination and positioning of the whole system.

**EXAMPLE: CR3D44  
LOAD CAPACITY CHART**

DOOR HEIGHT (mm / in)	DOOR WIDTH (mm / in)						
	700 27 7/8"	800 31 1/2"	900 35 7/8"	1000 39 3/4"	1100 43 3/8"	1200 47 1/4"	1300 51 3/8"
2200 86 3/4"	120 265	120 265	120 265	118 260	100 220	89 196	81 179
2100 82 1/8"	120 265	120 265	120 265	108 238	94 207	84 185	78 172
2000 78 3/4"	120 265	120 265	120 265	100 220	88 194	80 176	74 163
1900 74 13/16"	120 265	120 265	109 240	93 205	83 183	76 168	71 157

DOOR HEIGHT (mm / in)	DOOR WIDTH (mm / in)							4 HINGES SUGGESTED
	700 27 7/8"	800 31 1/2"	900 35 7/8"	1000 39 3/4"	1100 43 3/8"	1200 47 1/4"	1300 51 3/8"	
3000 118 1/4"	135 265	135 265	135 265	135 265	135 265	135 265	135 265	135 265
2900 114 9/16"	135 265	135 265	135 265	135 265	135 265	135 265	135 265	135 265
2800 110 1/4"	135 265	135 265	135 265	135 265	135 265	135 265	135 265	126 278
2700 106 7/16"	135 265	135 265	135 265	135 265	135 265	135 265	135 265	118 260
2600 102 3/4"	135 265	135 265	135 265	135 265	135 265	135 265	128 282	110 243
2500 98 7/16"	135 265	135 265	135 265	135 265	135 265	135 265	119 262	104 229
2400 94 1/2"	135 265	135 265	135 265	135 265	130 287	110 243	110 243	98 216
2300 90 7/16"	135 265	135 265	135 265	135 265	119 262	103 227	103 227	93 205
2200 86 3/4"	135 265	135 265	135 265	132 291	110 243	97 214	97 214	88 194
2100 82 1/16"	135 265	135 265	135 265	120 265	103 227	92 203	92 203	84 185
2000 78 3/4"	135 265	135 265	135 265	110 243	96 212	87 192	87 192	80 176

All CRP 3D hinges follow the standard regulations and passes all the necessary tests of stress, corrosion resistance, fire resistance, flow and durability.

Even though the 3D hinges are maintenance-free, for an ideal performance, it is advisable to lubricate the hinge once every two years, or more, depending on the frequency of opening.

**FOURTH HINGE**

In some cases, the use of a fourth hinge may be decisive for the capacity.

More specifically, In case of big widths (>39" / >1000 mm) or heights (>106" / >2700 mm) when different forces are produced by leverage effect and center of gravity moves towards the lock side, the fourth hinge must be installed in the upper part of the door, because only in this position can it positively affect the weight capacity. CRP therefore advises to install 9 27/32" (250 mm) away from the hinge at the top. In case of door height >118" (3000mm) please contact technical department.

**PROPER PLACEMENT OF THE HINGES ON DOORS**

The less the distance between the two hinges placed at the two extremities of the door (independently of a third/fourth hinge between them), the more stress the hinges experience.

We strongly suggest following the center-to-center measurements reported aside.

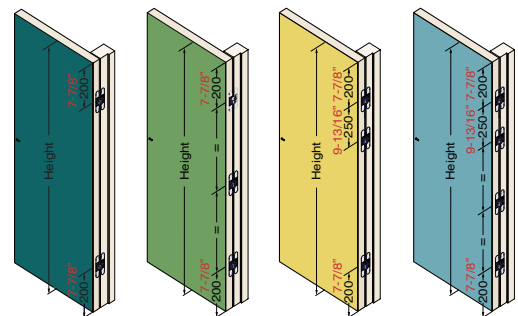

**DOOR CLOSERS**

When using door closers, CRP suggest installing a third or fourth hinge in the upper part of the door, as these mechanisms modify the opening forces, increase the load and may alter the capacity of the hinges. In particular:

- For closers without backcheck CRP suggest adding 20% on top of the real door weight
- For closers with backcheck the effect is much greater: CRP suggest adding 75% on top of the real door weight

**CALCULATION EXAMPLE:**

1. Real door weight: 154lbs (70kg)
2. Door closer with backcheck to be installed (+75%).  
Calculation 154lbs (70kg) \* 1.75 = 270lbs (122.50kg) is the actual weight to be considered for the proper system functionality.
3. Choose and proportion the hinges according to the load capacity charts reported in every technical datasheet.
4. Place the third or fourth hinge in the upper part, 9 27/32”(250mm) below the first hinge.  
For any doubt or special uses, please contact our technical department.

**DOOR STOPPERS OR FRAME/WALL PROTRUSIONS**

In some cases, a door stop, a handle hitting the wall or simply a protrusion of the wall/door frame can cause a leverage effect on the hinge joints which can lead to a system malfunction. It is advisable to install a door stop which can limit this leverage effect, and it is advisable to position it at a distance from the hinge equal to **75%** of the door width in the direction of the handle.

**3D ADJUSTMENTS**

The adjustment range is reported in every technical sheet and the instructions are placed in every box. Every adjustment requires adequate attention. The adjustment range indicated must be absolutely followed. Excessive force during adjustments can lead to possible malfunction that could cause system failure.

All CRP 3D hinges are delivered with all the adjustments centered (neutral position). After installation and after each adjustment all components must be tightened firmly but not excessively in order not to compromise functionality.

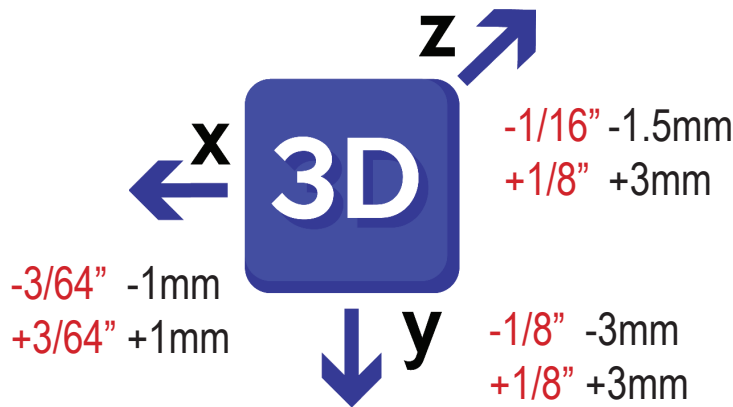

*Adjustment range varies according to different hinge models*

**NOTES**

The information herewith reported are indicative guidelines. In practice, the variables that affect the correct functioning of the hinge are several: according to the nature of the door, transit and employment, it can certainly be reasonable to analyze every single application. The customer must be sure hinges' proportions are enough to satisfy even external factors beyond what is indicated by tests. If necessary, please contact our technical department.