

# INSTALLATION INSTRUCTIONS FOR AF7700 SERIES FIRE EXIT DEVICE

## BEFORE INSTALLING DEVICE, PLEASE CHECK :

1. IF DOOR IS FITTED AND HUNG.
2. SIZE OF EXIT DEVICE, FUNCTION AND DESIGN...
  - 2.1. 36" DOORS, CAN BE CUT TO FIT DOORS DOWN TO 30" WIDE.
  - 2.2. 48" DOORS, CAN BE CUT TO FIT DOORS DOWN TO 36" WIDE.
  - 2.3. HAND OF DEVICE AGAINST APPLICATION.

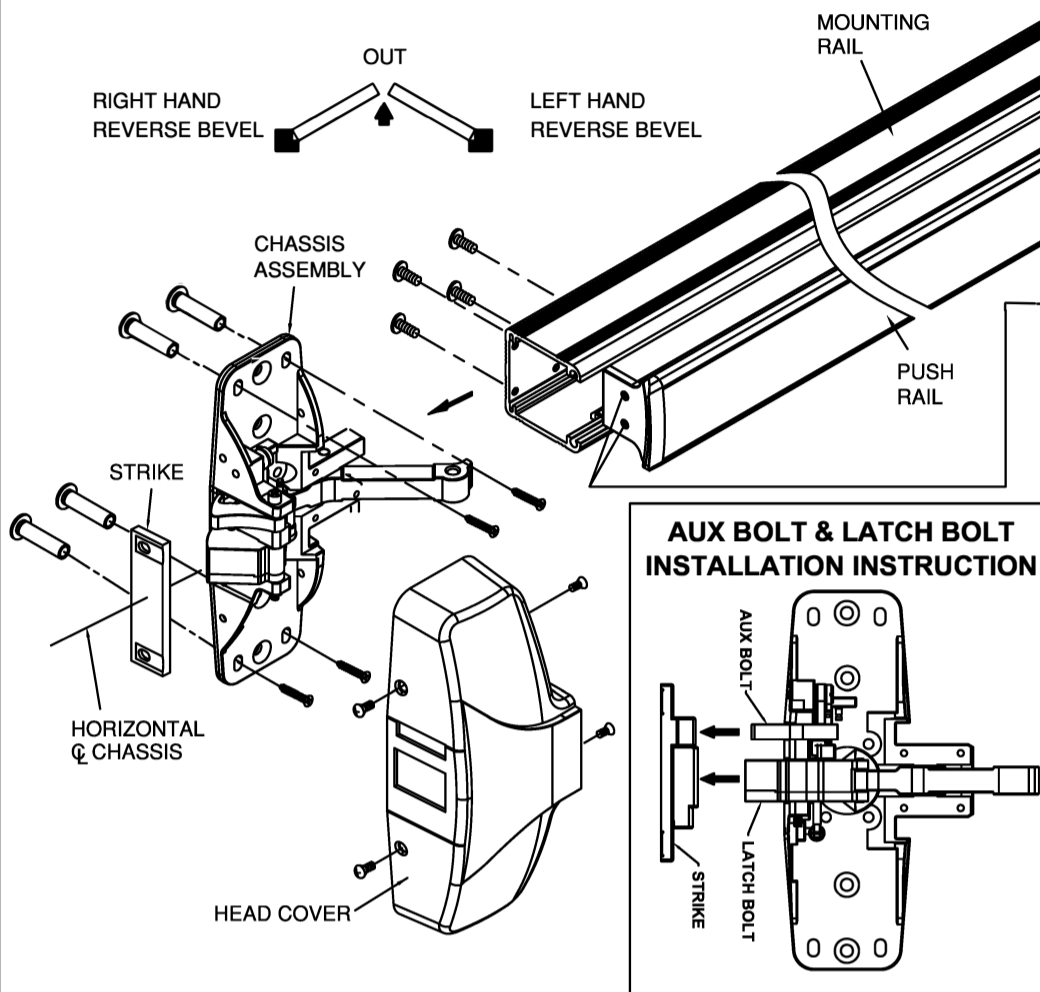

SURFACE OF DOOR FOR EXIT DEVICE APPLIED MUST BE FLUSHED.

PANIC BAR SET SCREWS (12-24 X 5/16") MUST BE ACTIVATED AT TOP AND BOTTOM OF PUSH RAIL TO ACHIEVE IMPACT RATING. SET SCREWS TO BE USED IN THE EVENT OF IMMINENT SEVERE WEATHER OF HURRICANE FORCE.

## 1. PREPARE DOOR

- 1.1 FOR 2 1/8" BORE PREP. POSITION TEMPLATE OVER EXISTING HOLE AND MARK FOR TWO CHASSIS MOUNTING SCREW HOLES.

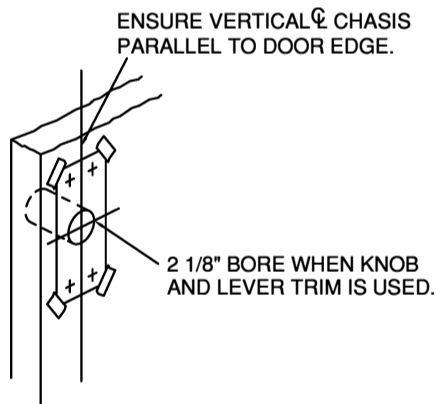

- 1.2 FOR DOOR W/O BORE PREP, MARK VERTICAL  $\phi$  CHASSIS AND HORIZONTAL  $\phi$  CHASSIS USING DIMENSIONS BELOW. MOUNTING SCREW HOLES.

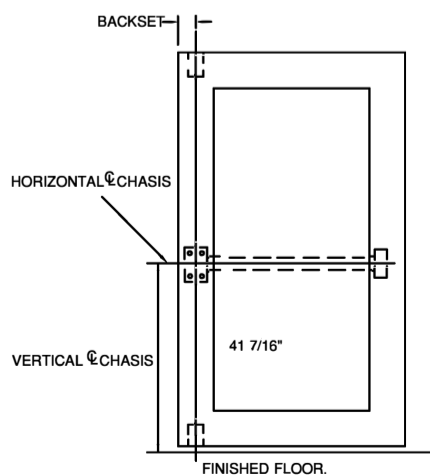

IDENTIFY TYPE OF INSTALLATION TO DETERMINE LOCATION OF VERTICAL  $\phi$

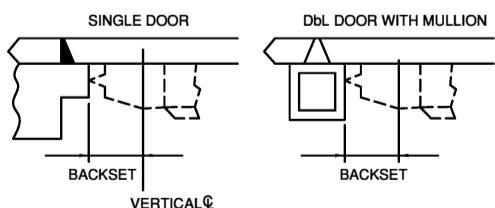

- STRIKE FOR BACKSET 2 1/4".
- STRIKE FOR BACKSET 1 3/4".
- STRIKE FOR BACKSET 2 1/4".
- STRIKE FOR BACKSET 1 1/2".

## 2. APPLY HARDWARE

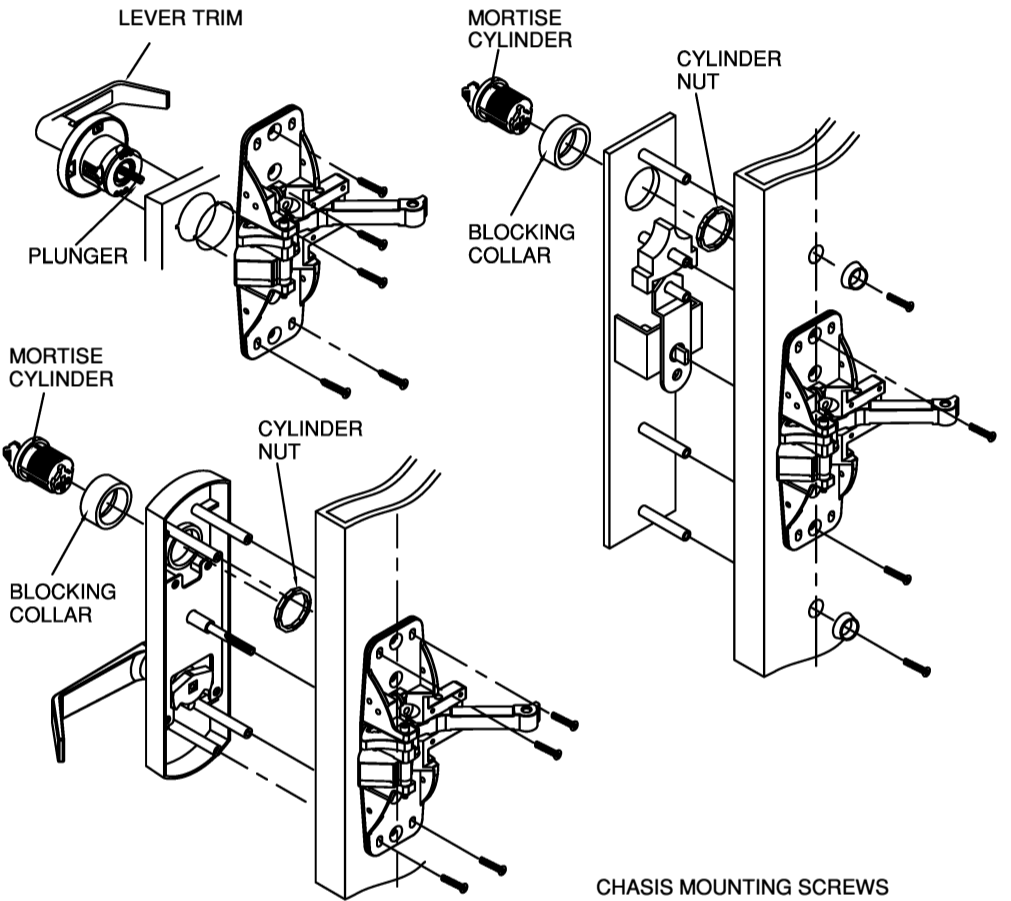

## 3. APPLY RAIL ASSEMBLY

- 3.1 CHECK THE SIZE OF DEVICE, IF CUTTING TO LENGTH IS REQUIRED.
- 3.2 DETERMINE CUT OFF LENGTH "X" BY SUBTRACTING 1-3/4" FROM "Y". MARK CUT OFF POINT ON MOUNTING RAIL.
- 3.3 DEPRESS ARM INTO RAIL OPENING AND SLIDE RAIL ONTO CHASSIS. LEVEL RAIL AND FASTEN CHASSIS AND MOUNTING PLATE.

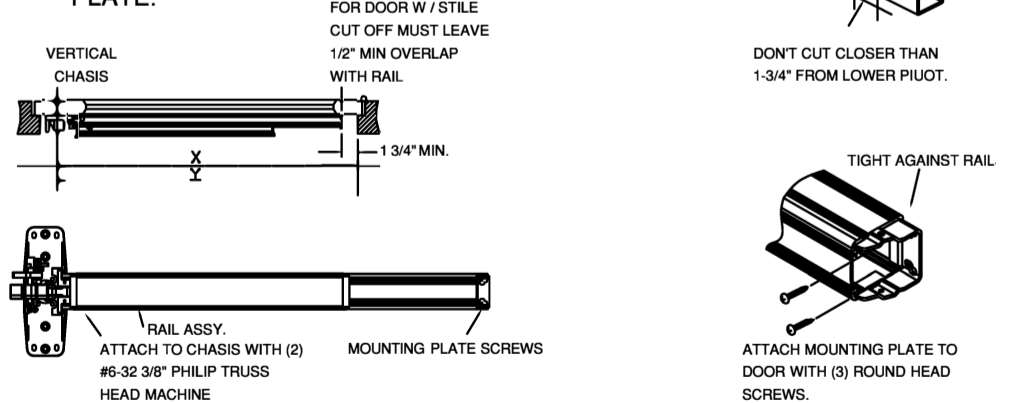

## 4. APPLY COVER AND STRIKES

