

DRILL 1"(25mm) HOLE
AT CENTER OF
DOOR EDGE

FOLD ON DOOR EDGE
FOLD ON DOOR EDGE

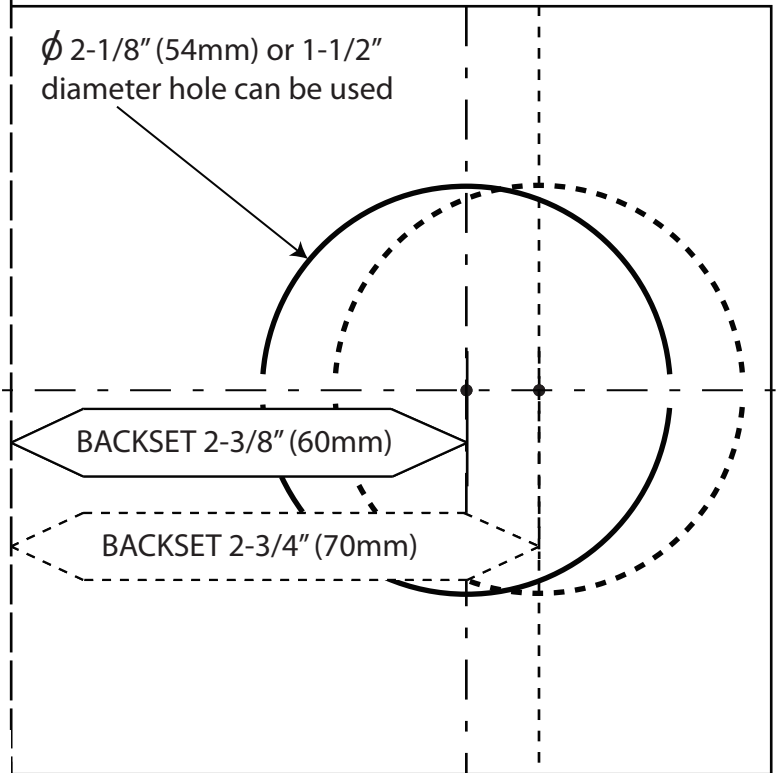
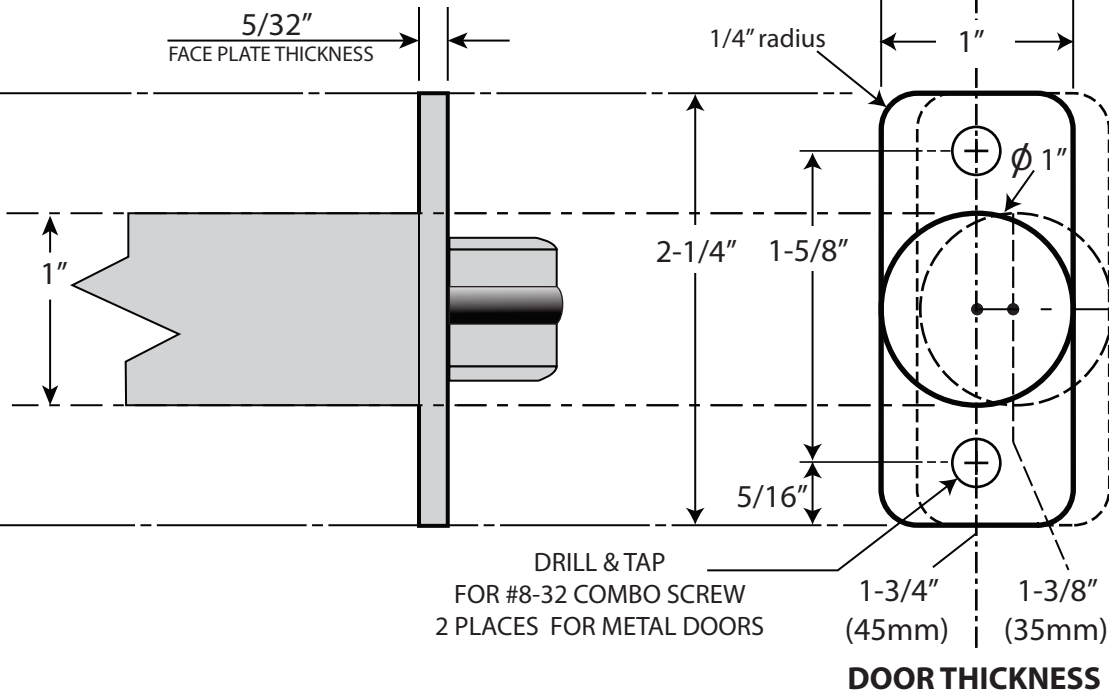

1. MARK DOOR

- A. Fold and apply to high edge of door bevel and mark center of door edge as indicated on template at the desired height from the floor.
- B. Mark center hole on door face through guide on template for 2-3/8" (60mm) or 2-3/4" (70mm) backset.

2. DRILL HOLES

- A. Drill thru door face as marked for lockset. It is recommended that holes be drilled from both sides to prevent splitting. Hole size is 2-1/8"(54mm) for standard installations.
 - B. Drill 1"(25mm) hole in center of door edge thru 2-1/8"(54mm) hole for latch.
- CAUTION: Check center of latch hole for alignment with strike center on jamb to ensure free movement of latch bolt.



6605 Flotilla St.
City of Commerce
CA 90040 USA
Tel: (323) 888-6601
FAX: (323) 888-6699
Website: cal-royal.com
Email: sales@cal-royal.com

ITEM NO.	DESCRIPTION	ANSI	SCALE	UNIT	VERSION
BRI-00	CHELSIE SERIES RESIDENTIAL TUBULAR LOCKSET FUNCTION: ENTRY	Grade 3	1 : 1	inches (mm)	ver. 1.0 rev. 01/12
			PAGE 1 OF 1		BY: bteves