

BUTT HUNG	A	B	C
90°	73	120.6	45



88 SERIES CONCEALED OVERHEAD DOOR CLOSER 88-JO INSTALLATION INSTRUCTIONS

I HEADER PREPRARATION

- A. DIM A MUST BE MAINTAINED FROM JAMB TO CENTER LINE OF SPINDLE.
- B. 'F' MUST BE MAINTAINED FROM PIVOT SIDE OF HEADER TO CL OF SPINDLE REGARDLESS OF HEADER WIDTH.
- C. FOR MORE DETAILS REFER TO TEMPLATE #10-137

II DOOR PREPARTION (BUTT HINGE)

- A. ROUTE TOP OF DOOR FOR SLIDE CHANNEL INSTALLATION.(DETAIL A-A). ON ALUM DOORS. SPACERS MAT NEEDED TOMAINTAIN REQ. 23mm DIM. SEE X-X.
- B. ROUTING IS NEEDED ON STOP SIDE OF DOOR FOR ARM CLEARANCE . SEE B-B.
- C. PREPARE DOOR FOR BUTTS AS NORMAL.

III DOOR INSTALLATION

- A. SET ON PIVOTS,ADJUST FOR CLEARANCES.

IV COMPLETE INSTALLATION

- A. MOUNT ARM ON SPINDLE AND SECURE WITH 1/4-20*7/8\"/>
- B. OPEN DOOR AND ACTUATE ARM INTO OPEN POS. SLIP AARM OVER SLIDE PIN AND SECURE WITH PIN RETAINER.
- C. ADJUST CLOSER TO DESIRED DOOR SPEED. INSTALL ARM COVER WITH SCREWS PROVIDED.

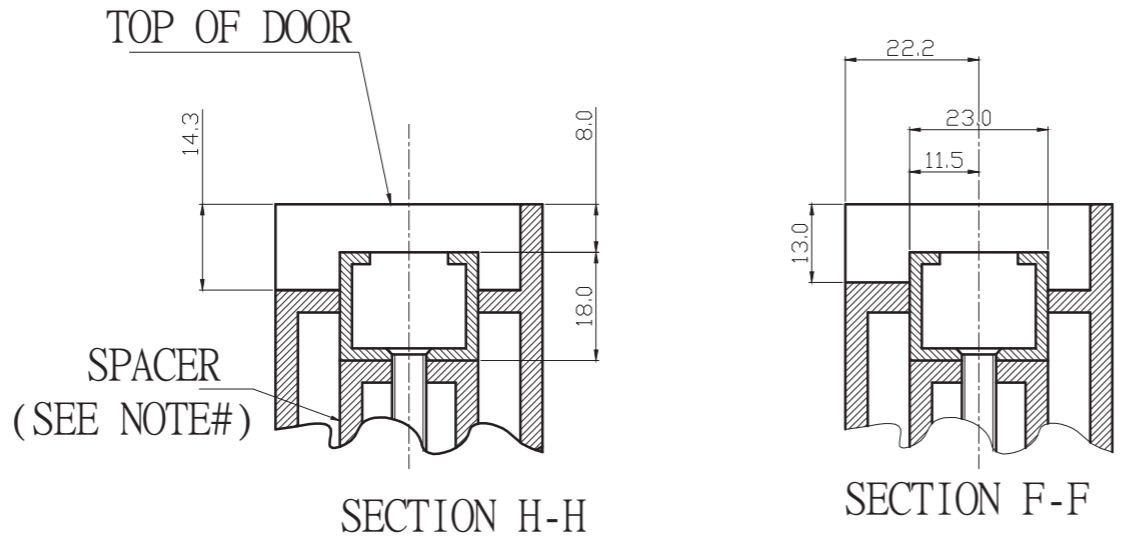

NOTE:
DOOR MFG. TO SUPPLY
ARPPROPRIATE SPACER
& BACK-UP PLATES
CHAMFER ALL 3 TAP HOLES
ON SPACER : C1

