

**INSTALLATION INSTRUCTIONS for
Dorco series Surface mounted COORDINATOR**

Note: Install Coordinator before installing any other Hardware including locksets, except Hinges.

1. Close the door against stop. Locate the active and inactive strikes as shown in Fig.1.
2. Locate Dorco Series Coordinator shown in Fig 2 & 4. Drill mounting hole with #10 drill. Install 12-14 thread forming screws to hold Coordinator in correct position before drilling other holes. As to the installing hole dimensions in different sizes, varied from the door sizes, See Fig.2.
3. As may be varied from the door sizes, install filler Bar supplied as shown in Fig.3. to complete fill opening between end of Coordinator and face of inactive door stop

Fig.1. Active and inactive door strike plates



Fig.2. Coordinator with doors in closed position

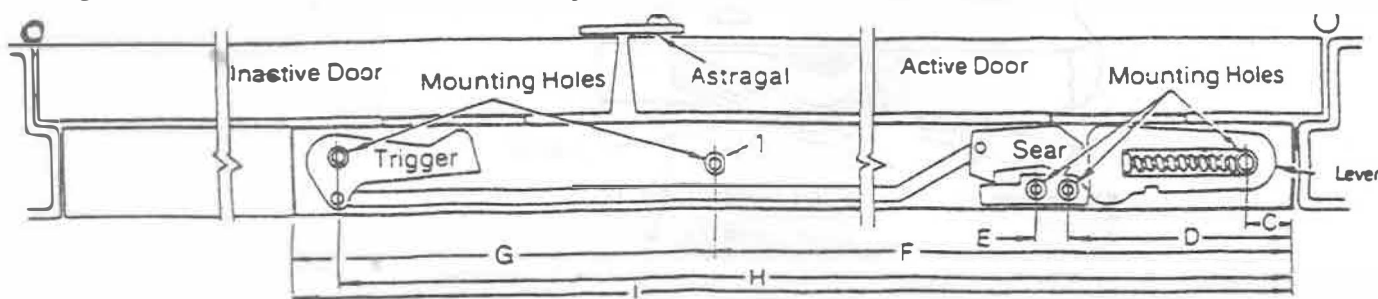

Length of Housing	dimension in inches									
	A	B	C	D	E	F	G	H	I	J
32"	1-1/4	27-1/2	7/8	4	3/4			31	32	Cuttable per door size variations
52"	1-1/4	47-1/2	7/8	4	3/4	27-5/8	24-3/8	51	52	
60"	1-1/4	55-1/2	7/8	4	3/4	27-5/8	32-3/8	59	60	

Fig. 3. Coordinator with Filler Bar Doors in open position.

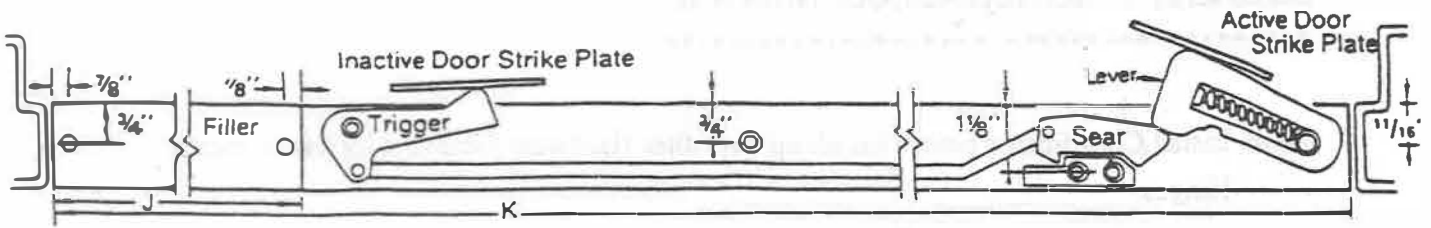

Fig. 4. Doors in closed position

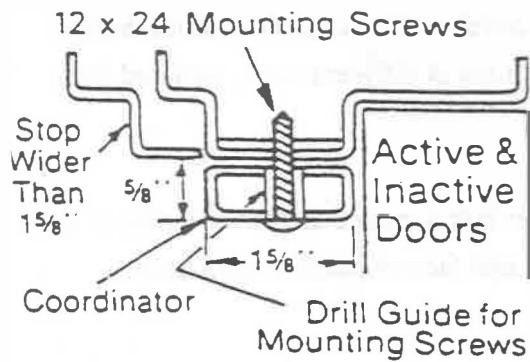
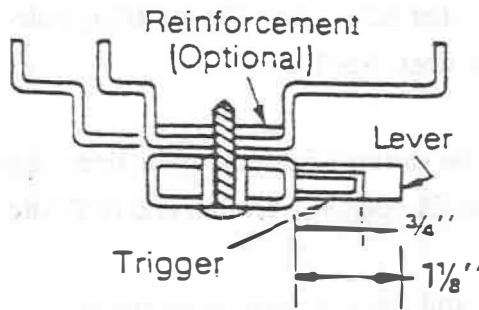

Fig. 5. Doors in open position, Lever and Trigger projection



Note: Pre-set tension on lever torsion spring holds active door open until trigger depressed by closing of inactive door.

If active door overrides lever before trigger depressed, increase tension on spring as shown in Fig. 6.

Fig. 6.

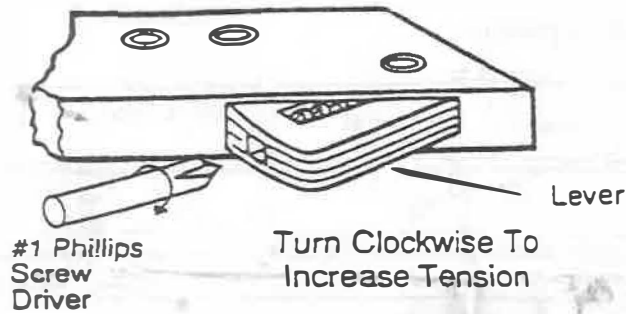

CAL-ROYAL

PRODUCTS, INC.

2110 TUBEWAY AVE.
CITY OF COMMERCE, CALIFORNIA • 90040 • U.S.A.
PHONE: 213-888-6601 • FAX 213-888-6699