

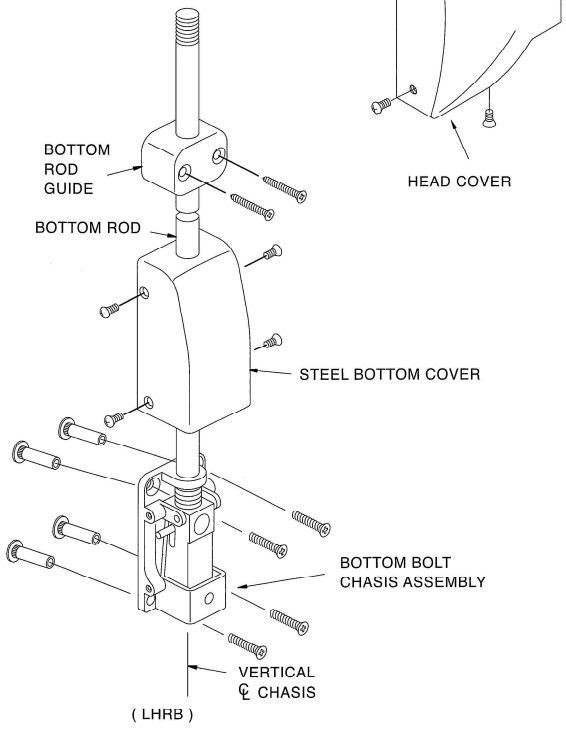

# INSTALLATION INSTRUCTION FOR F5000V SERIES FIRE-RATED VERTICAL EXIT DEVICE

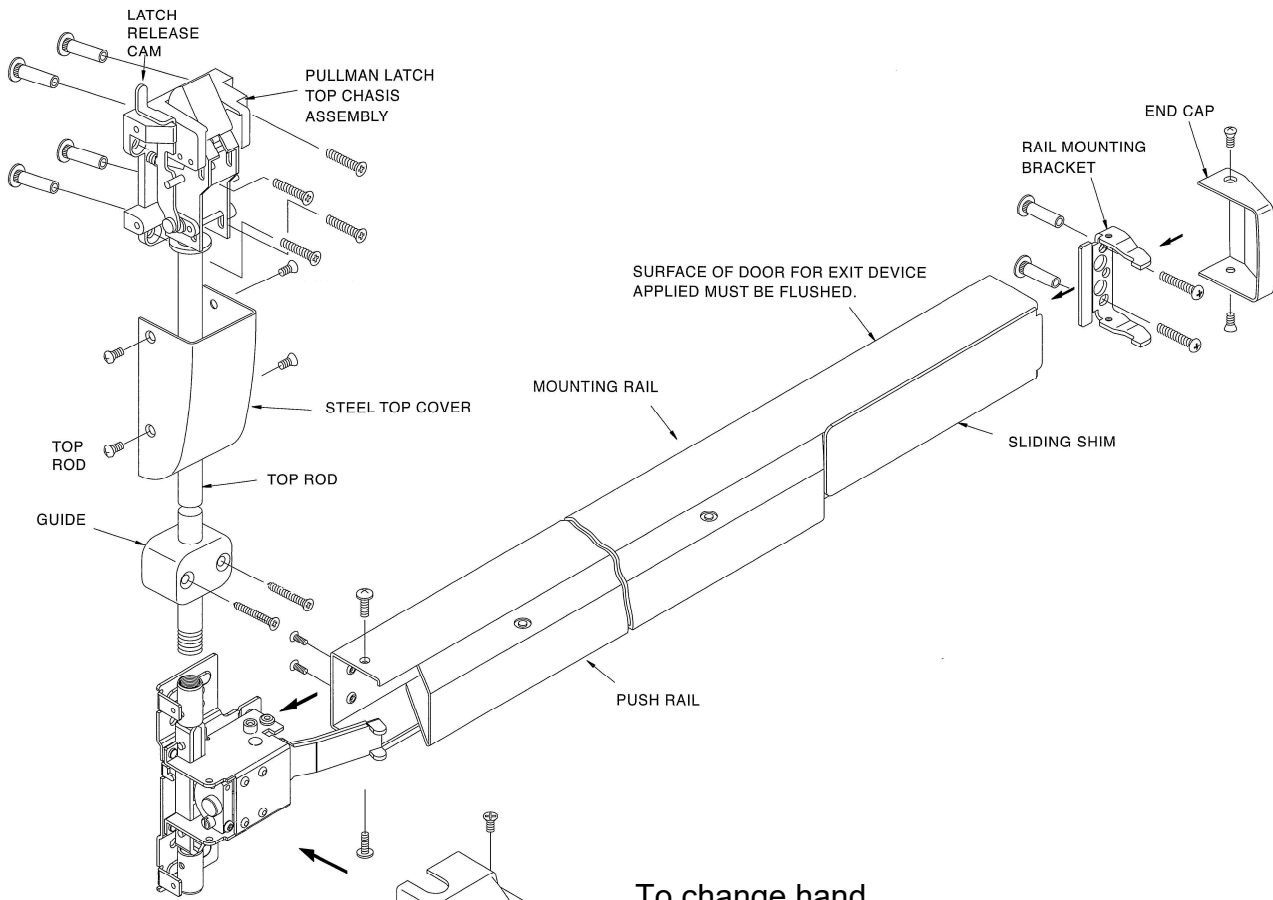
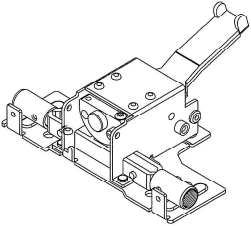
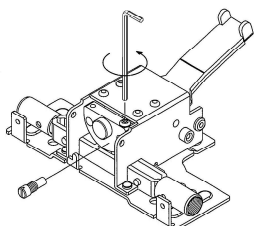
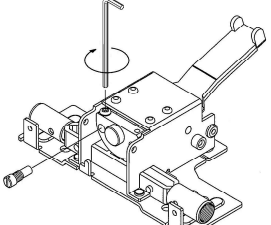
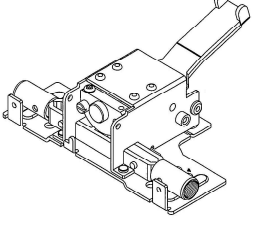

## To change hand

<p>1. Factory pre-set RHR</p>	<p>2. Unfasten philip and flat head screw from the pre-set RHR</p>
	
<p>3. Fasten philip and flat head screws to the other end for LHR</p>	<p>4. Now already changed to LHR</p>
	

# 1. MARK VERTICAL AND HORIZONTAL REFERENCE LINE ON DOOR.

DETERMINE BACKSET LOCATE VERTICAL REFERENCE LINE.

1. IF LOCK STILE IS 4 1/2" WIDE OR WIDER, BACKSET IS 2 3/4".
2. IF LOCK STILE IS LESS THAN 4 1/2" WIDE, BACKSET IS HALF OF THE EXPOSED WIDTH OF DOOR STILE.

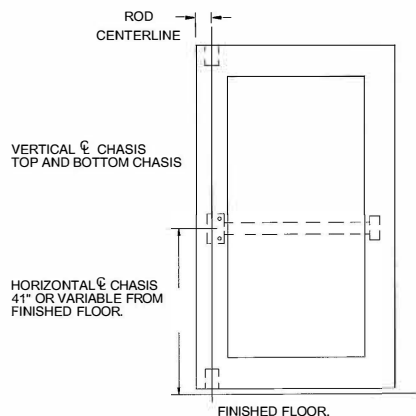

# 2. PREPARE DOOR

TAPE TEMPLATE ON INSIDE OF DOOR ALONG REFERENCE LINE. SPOT AND DRILL HOLE.

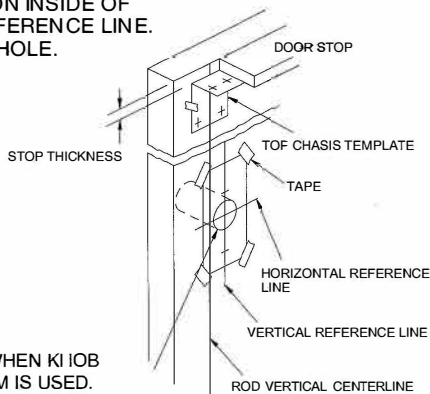

2-1/8" Ø BORE WHEN K1 JOB AND LEVER TRIM IS USED.

# 3. APPLY TRIM+CHASIS

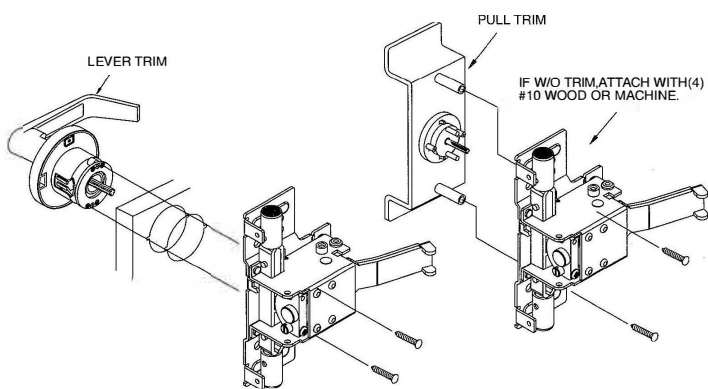

BEFORE INSTALLING DEVICE, PLEASE CHECK :

1. IF DOOR FITTED AND HUNG.
2. SIZE OF EXIT DEVICE, FUNCTION AND DESIGN...
  - 2.1. 36" DOORS, CAN BE CUT TO FIT DOORS DOWN TO 30" WIDE.
  - 2.2. 48" DOORS, CAN BE CUT TO FIT DOORS DOWN TO 36" WIDE.
  - 2.3. HAND OF DEVICE AGAINST APPLICATION

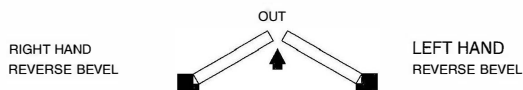

# 4. ATTACH TOP AND BOTTOM CHASIS

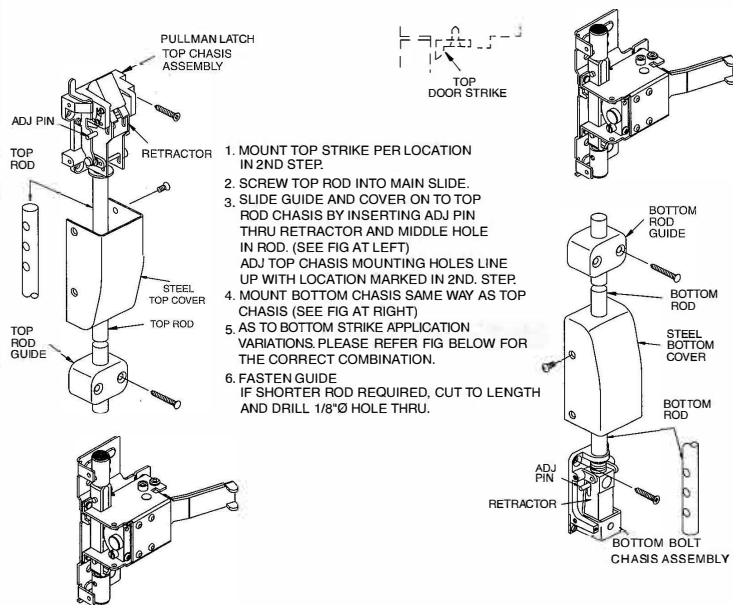

1. MOUNT TOP STRIKE PER LOCATION IN 2ND STEP.
2. SCREW TOP ROD INTO MAIN SLIDE.
3. SLIDE GUIDE AND COVER ON TO TOP ROD CHASIS BY INSERTING ADJ PIN THRU RETRACTOR AND MIDDLE HOLE IN ROD. (SEE FIG AT LEFT) ADJ TOP CHASIS MOUNTING HOLES LINE UP WITH LOCATION MARKED IN 2ND. STEP.
4. MOUNT BOTTOM CHASIS SAME WAY AS TOP CHASIS (SEE FIG AT RIGHT)
5. AS TO BOTTOM STRIKE APPLICATION VARIATIONS, PLEASE REFER FIG BELOW FOR THE CORRECT COMBINATION.
6. FASTEN GUIDE IF SHORTER ROD REQUIRED, CUT TO LENGTH AND DRILL 1/8" Ø HOLE THRU.

# 5. APPLY RAIL ASSEMBLY

6. CHECK THE SIZE OF DEVICE, IF LENGTH REDUCING IS REQUIRED.
7. DETERMINE CUT OFF LENGTH "X" BY SUBTRACTING 1 3/4" FROM "Y". MARK CUT OFF POINT ON MOUNTING RAIL.

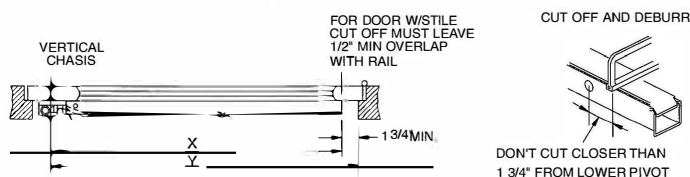

3. DEPRESS ARM INTO RAIL OPENING AND SLIDE RAIL ONTO CHASIS. LEVEL RAIL AND FASTEN CHASIS AND MOUNTING PLATE.

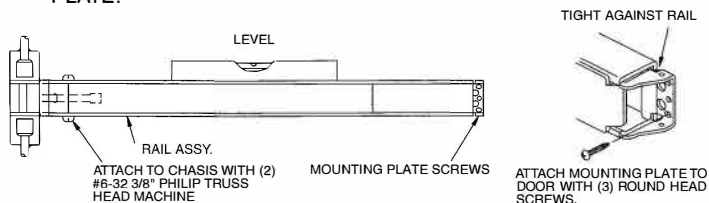

# 6. APPLY COVER

CHECK FINAL OPERATION OF DEVICE AND ADJUST THEN FASTEN COVERS.

