

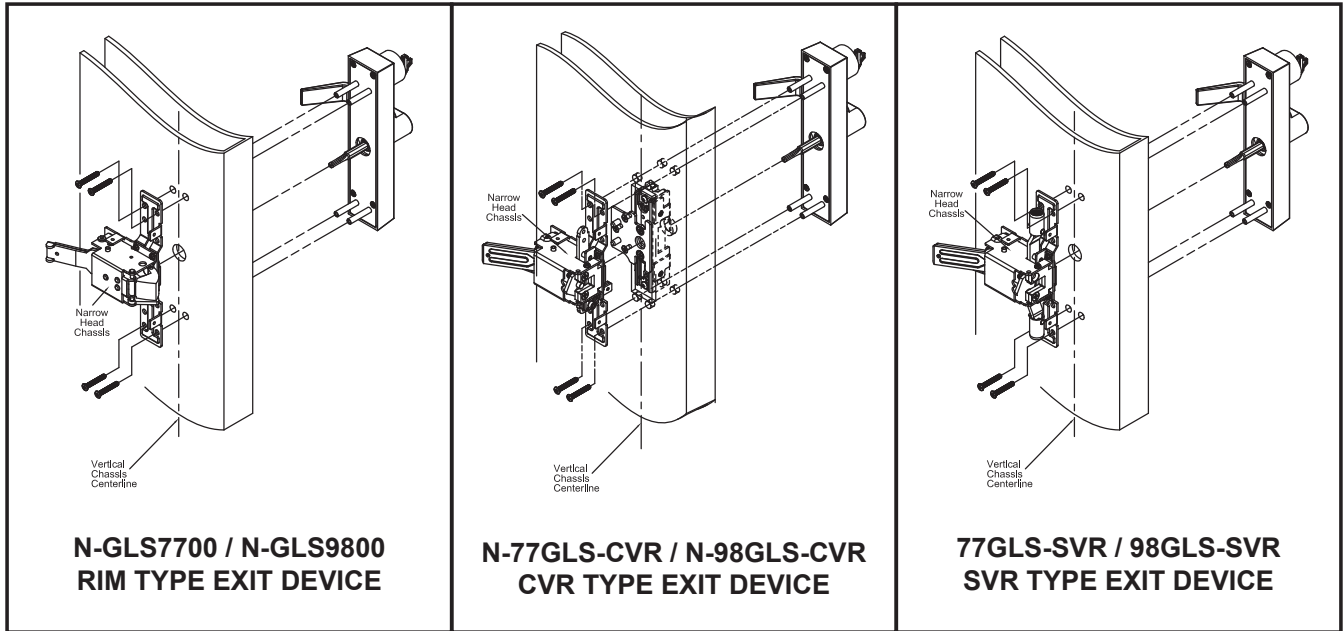

# GLSESC TRIM INSTALLATION INSTRUCTIONS

## for Narrow Stile RIM, SVR, CVR Exit Devices

( N-GLS7700 / N-FGLS7700, 77GLS-SVR / F77GLS-SVR, N-77GLS-CVR, N-F77GLS-CVR, N-GLS9800 / N-FGLS9800, 98GLS-SVR / F98GLS-SVR, N-98GLS-CVR, N-F98GLS-CVR )



GLSESC-00	GLSESC-30	GLSESC-40	GLSESC-05
<p>Lockable escutcheon lever trim. Key locks and unlocks lever.</p>	<p>No cylinder, Trim always operable.</p>	<p>Pull when push bar is pressed down dummy lever Trim.</p>	<p>Key unlock escutcheon lever, key remains in cylinder unless locked.</p>
13 function Entrance	15 function Passage	10 function Dummy	04 function Storeroom

# GLSESC LEVER TRIM FOR ESCUTCHEON HOW TO CHANGE HANDING OF LEVER RHR

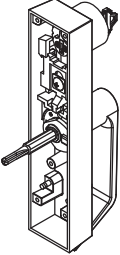
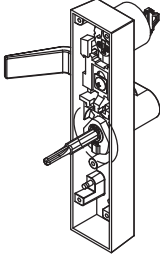
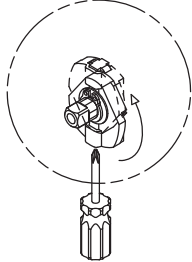
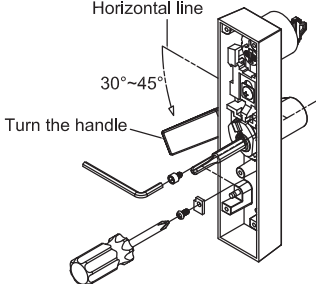
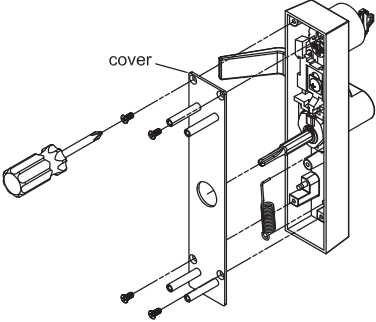
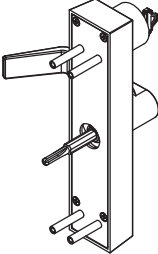
<p>1.Lever trim shipped and supplied with lever positioned neutral, Non-Handed</p> 	<p>2.Rotate lever to desired hand, RHR position at 90°.</p> 	<p>3-1.Depress &amp; Push in the spring loaded locking piece in the "up" position to rotate hub. 3-2.Make sure spring loaded locking piece click in place &amp; is in line with locking slide to operate.</p> 
<p>4-1.Fasten stop screw on the other side using hex wench. 4-2.Fasten guide stop plate to case at the same side of hub spring.</p> <p>Horizontal line 30°~45° Turn the handle</p> 	<p>5-1.Mount the hub spring on the opposite groove pin. 5-2.Fasten cover to case.</p> <p>cover</p> 	<p>6.Done</p> 

**Method for replacing cylinder.**

- 1.With locking slide in down position, unscrew cylinder nut and remove the cylinder and ring.
- 2.Replace cylinder by reversing above procedure. Make sure that cylinder cam points up and correct length of ring is used.

# GLSESC LEVER TRIM FOR ESCUTCHEON HOW TO CHANGE HANDING OF LEVER LHR

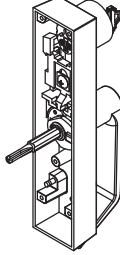
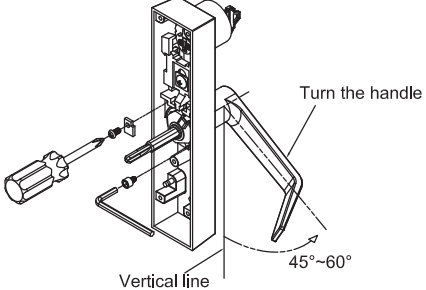
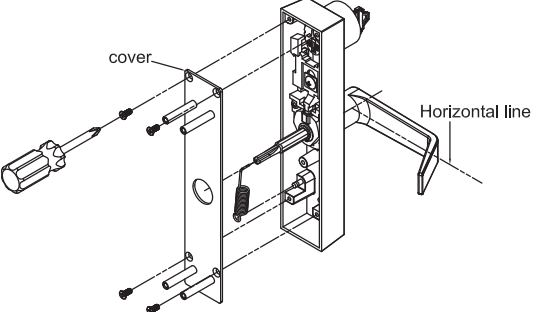
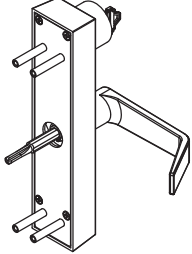
<p>1.Lever Trim shipped and supplied with lever positioned neutral, Non-Handed</p> 	<p>2-1.Rotate lever handle to LHR, position lever 45°~60°. 2-2.Fasten stop screw on the other side using hex wench. 2-3.Fasten guide stop plate to case at the same side of hub spring.</p> <p>Turn the handle Vertical line 45°~60°</p> 
<p>3-1.Mount the hub spring on the opposite groove pin. 3-2.Fasten cover to case.</p> <p>cover Horizontal line</p> 	<p>4.Done.</p> 

**Method for replacing cylinder.**

- 1.With locking slide in down position, unscrew cylinder nut and remove the cylinder and ring.
- 2.Replace cylinder by reversing above procedure. Make sure that cylinder cam points up and correct length of ring is used.