

HDHB40

HEAVY DUTY HANDRAIL BRACKET

Features

- Individually poly-bagged with screws
- Comparable to IVES #059

Height

- 3 1/4"

Projection

- 3 1/4"

Material

- Die Cast Aluminum

Finishes

- US3 - Polished Brass
- US5 - Antique Brass
- US10B - Oil Rubbed Bronze
- US15 - Satin Nickel
- US15A - Antique Nickel
- US26 - Polished Chrome
- US26D - Satin Chrome
- US1 - Black

Code Compliance

- Conforms to ANSI/BHMA A156.16 L33061

Fastener

- WOOD SCREWS
 - #7 x 1" Phillips Round Pan (2)
 - #7 x 1-1/2" Phillips Raised Countersunk (3)



HDHB40

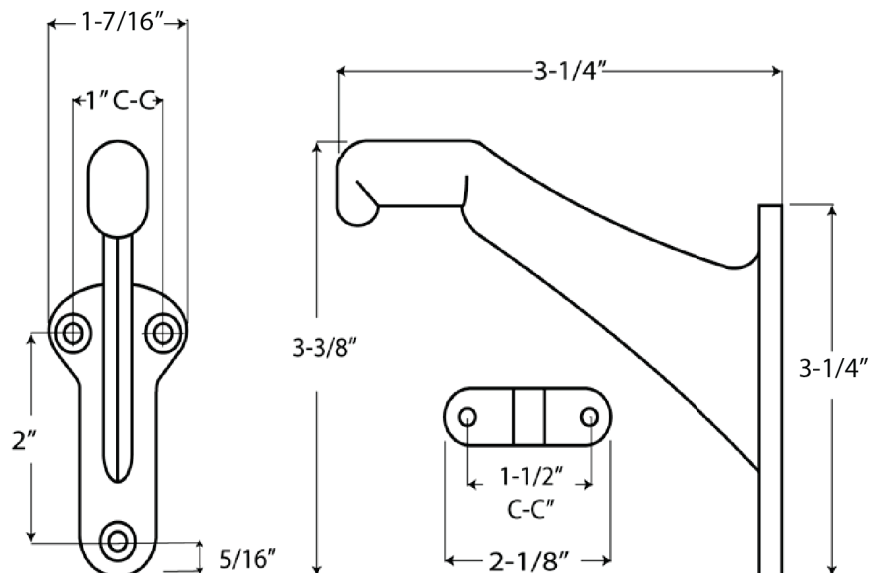

CAL-ROYAL PRODUCTS, INC.

6605 Flotilla St., City of Commerce, CA 90040 U.S.A.
Phone: (323) 888-6601 • (800) 876-9258 • Fax: (323) 888-6699 • (800) 222-3316
Email: sales@cal-royal.com • Website: www.cal-royal.com

The illustration and technical description in this cut sheet is current as of the date in the version date on the right. Cal-Royal Product reserves the right to, and may, on occasions, make changes and/or improvements in designs and dimensions without prior notice.

2019/01
VERSION NO. 7
YEAR PRINTED

© Cal-Royal Products, Inc. 2019