

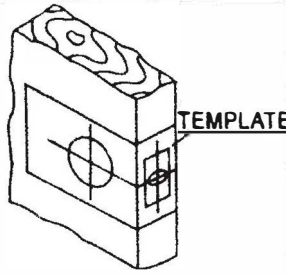

# HOW TO INSTALL THIS TUBULAR LOCK

<p><b>1 MARK DOOR</b></p>  <p>• Mark site of lock and bore.</p>	<p><b>2 BORE HOLES</b></p>  <p>• Bore the holes through door •• Cut out base.</p>	<p><b>3 INSTALL LATCH</b></p> 	<p><b>4 INSTALL OUT - KNOB</b></p>  <p>Key hole should be in down position.</p>
<p><b>5 INSTALL IN-KNOB</b></p> 	<p><b>6 INSTALL STRIKE</b></p>  <p>Line of door thickness</p>	<p><b>INSTRUCTION FOR ADJUSTABLE LATCH</b></p>  <p>The cam is pushed fully to the right for 70mm (2 3/4") backset. (During the adjustment, keeping two teeth of the cam to forward always.)</p> <hr/>  <p><b>ADJUST PART</b> Push the latch inward, take off the adjust part for 70mm (2 3/4") backset.</p> 	

## PAPER MARKER

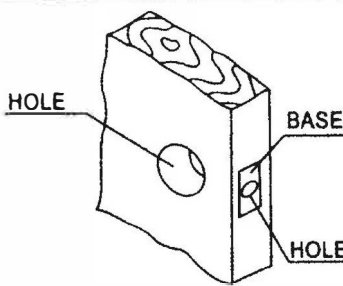
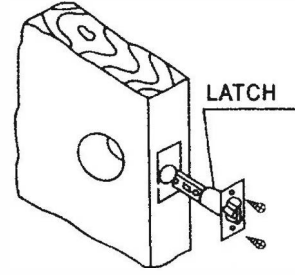
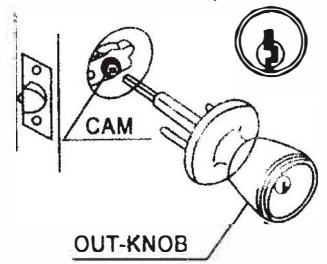
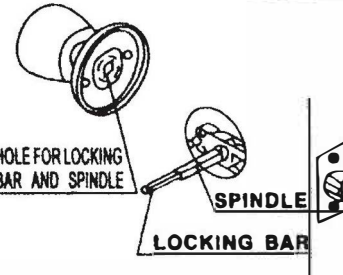
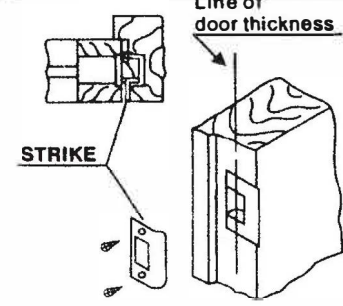
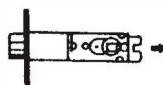
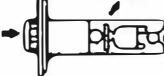