

INSTALLATION INSTRUCTION FOR F9900V SERIES FIRE VERTICAL ROD EXIT DEVICE.

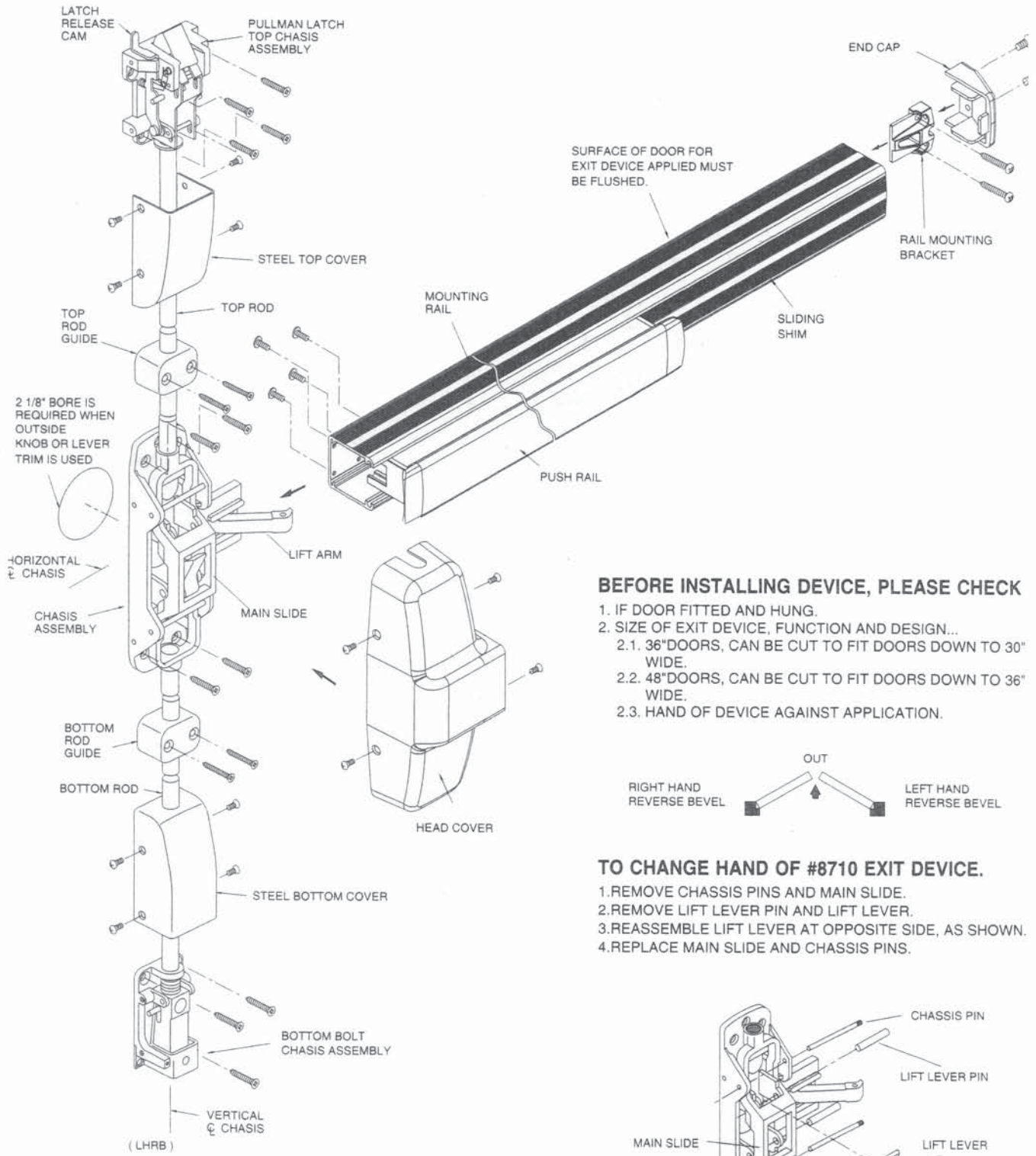

BEFORE INSTALLING DEVICE, PLEASE CHECK

1. IF DOOR FITTED AND HUNG.
2. SIZE OF EXIT DEVICE, FUNCTION AND DESIGN...
 - 2.1. 36" DOORS, CAN BE CUT TO FIT DOORS DOWN TO 30" WIDE.
 - 2.2. 48" DOORS, CAN BE CUT TO FIT DOORS DOWN TO 36" WIDE.
 - 2.3. HAND OF DEVICE AGAINST APPLICATION.



TO CHANGE HAND OF #8710 EXIT DEVICE.

1. REMOVE CHASSIS PINS AND MAIN SLIDE.
2. REMOVE LIFT LEVER PIN AND LIFT LEVER.
3. REASSEMBLE LIFT LEVER AT OPPOSITE SIDE, AS SHOWN.
4. REPLACE MAIN SLIDE AND CHASSIS PINS.

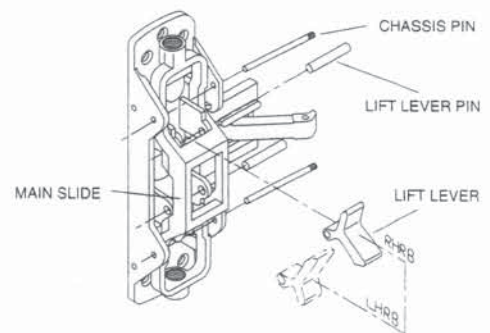

1. MARK VERTICAL AND HORIZONTAL REFERENCE LINE ON DOOR.

DETERMINE BACKSET TO LOCATE VERTICAL REFERENCE LINE.

1. IF LOCK STILE IS 4-1/2" WIDE OR WIDER, BACKSET IS 2-3/4".
2. IF LOCK STILE IS LESS THAN 4-1/2" WIDE, BACKSET IS HALF OF THE EXPOSED WIDTH OF LOCK STILE

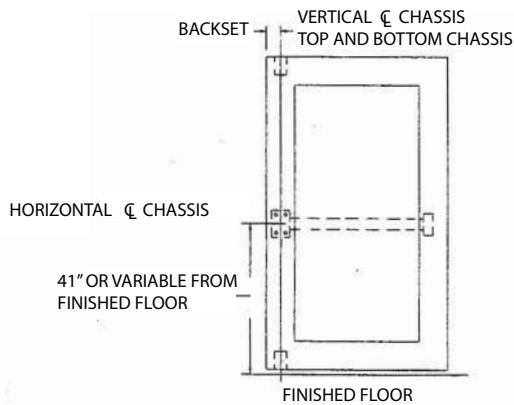

4. ATTACH TOP AND BOTTOM CHASSIS

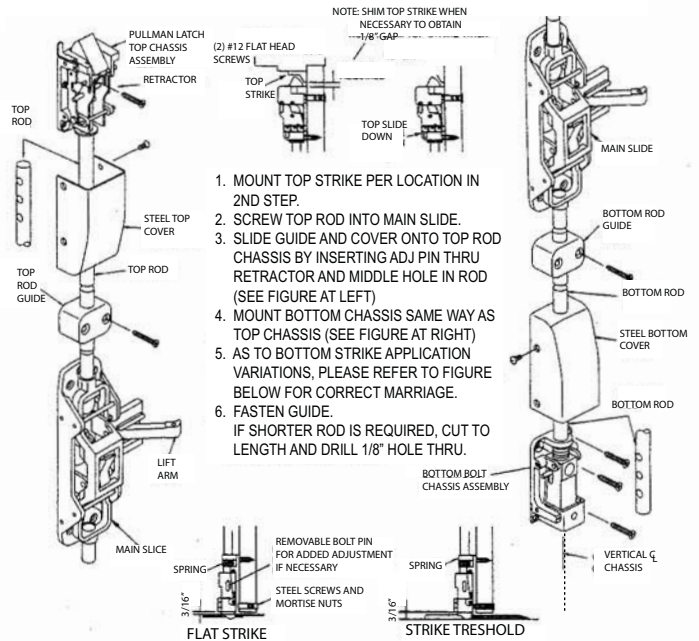

2. PREPARE DOOR

TAPE TEMPLATE ON INSIDE OF DOOR ALONG REFERENCE LINE.
SPOT AND DRILL HOLE.

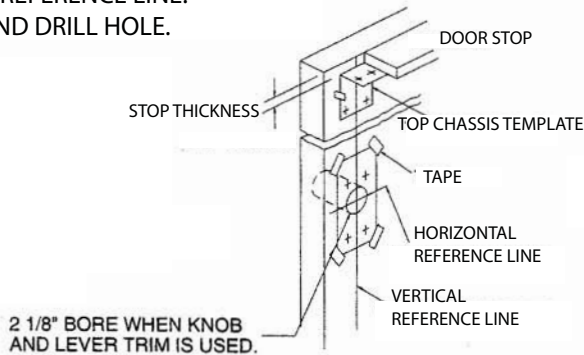

5. APPLY RAIL ASSEMBLY

1. CHECK THE SIZE OF DEVICE, IF CUTTING TO LENGTH IS REQUIRED.
2. DETERMINE CUT OFF LENGTH "X" BY SUBTRACTING 1-3/4" FROM "Y". MARK CUT OFF POINT ON MOUNTING RAIL.

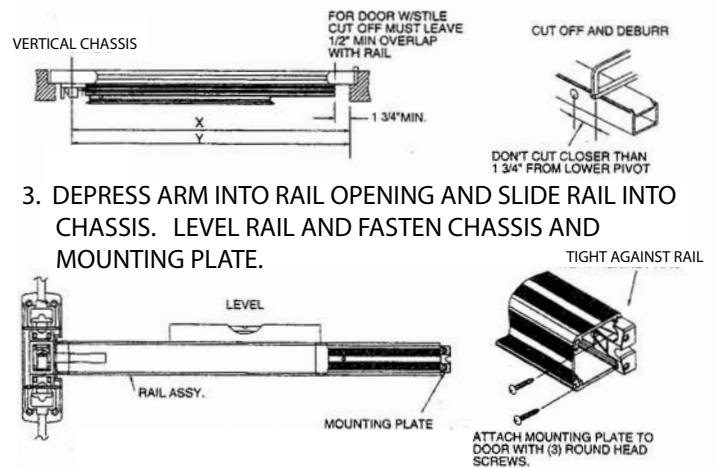

3. APPLY HARDWARE

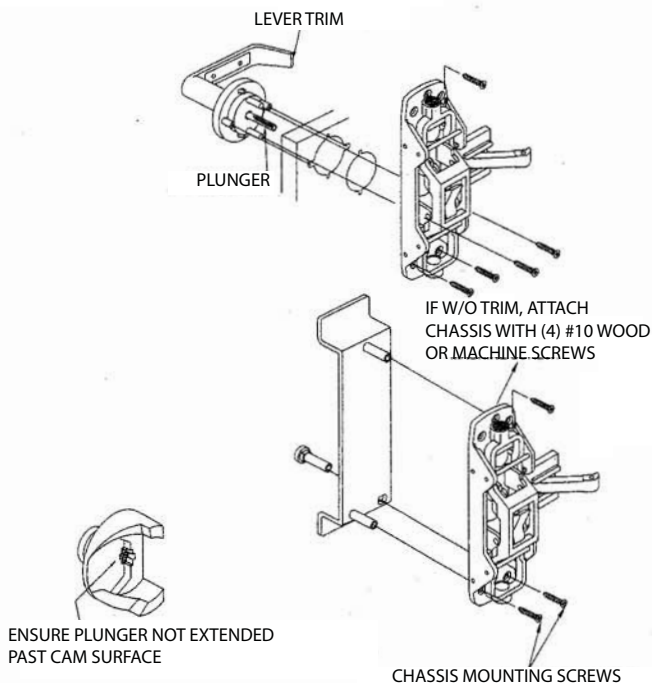

6. APPLY COVER

CHECK FINAL OPERATION OF DEVICE AND ADJUST, THEN FASTEN COVERS.

