

REGULAR ARM (PULL/HINGE SIDE) MOUNTING

TEMPLATE SHOWN IS FOR RIGHT HAND DOOR. FOR LEFT HAND DOOR USE OPPOSITE LOCATION

TOP VIEW REGULAR ARM INSTALLATION

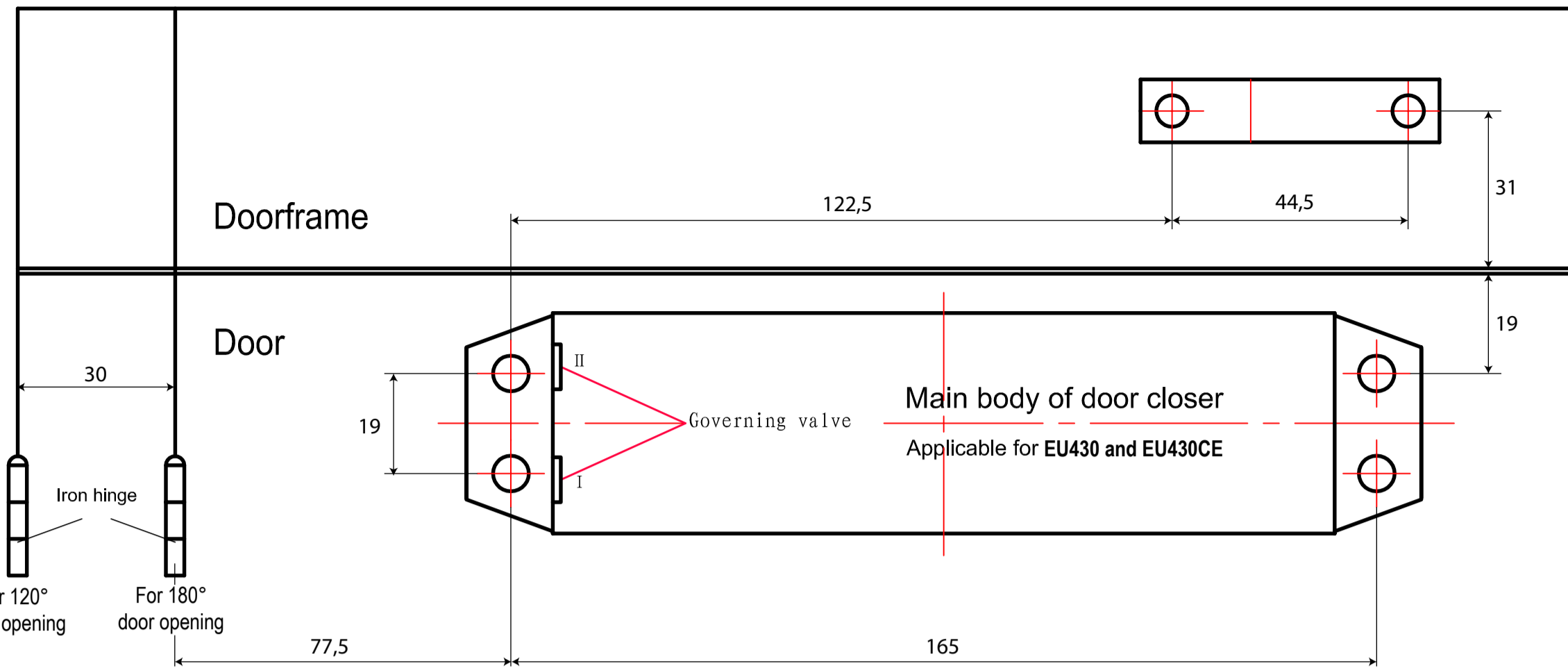
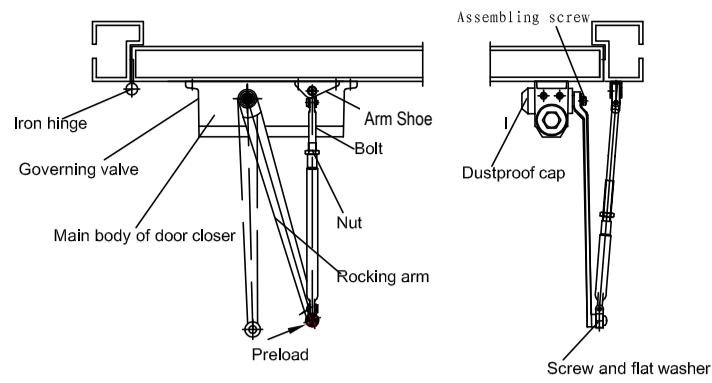

TOP VIEW TOP JAMB INSTALLATION

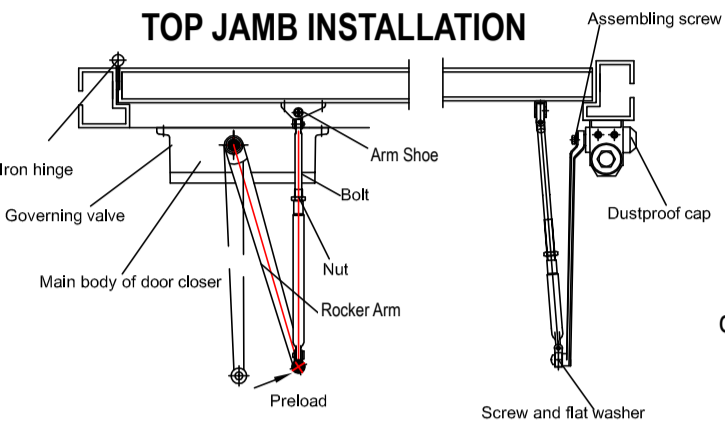

TOP JAMB (PUSH SIDE) INSTALLATION

TEMPLATE SHOWN IS FOR LEFT HAND DOOR. FOR RIGHT HAND DOOR USE OPPOSITE LOCATION

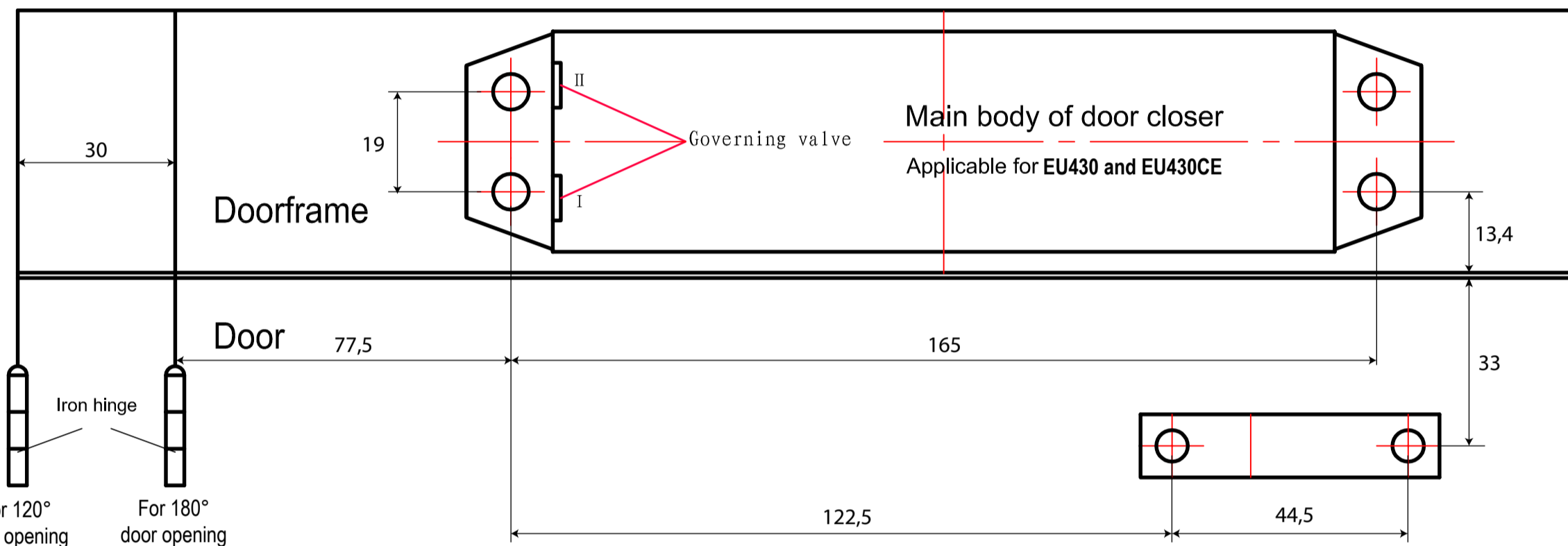

INSTALLATION INSTRUCTIONS

1. Depending on the type of installation, cut the corresponding template and affix it on the door and door frame location. Mark and drill holes.
2. Mount closer body on the door or door frame and secure with mounting screws. Make sure that the governing valves are facing to the location of the hinges.
3. Remove the screw and flat washer from the rocking arm and bolt. Position the arm shoe on the door or door frame, and secure with mounting screws.
4. Install rocker arm onto the top pinion nut with screw provided.
5. Adjust the length of the adjustable forearm so that it is perpendicular to the door or door frame when assembled to preloaded main arm. Secure forearm to main arm by tightening the nut.
6. Snap dustproof cap cover over pinion nut.

PARALLEL ARM (PUSH SIDE) INSTALLATION

TEMPLATE SHOWN IS FOR LEFT HAND DOOR. FOR RIGHT HAND DOOR USE OPPOSITE LOCATION

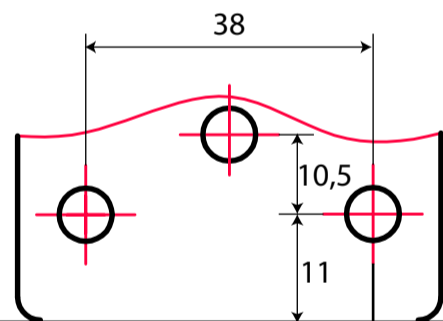

EU430 EU430CE

1. Cut PARALLEL ARM TEMPLATE and affix it on the door and door frame location. Mark and drill holes.
2. Mount closer body on the door or door frame and secure with mounting screws. Make sure that the governing valves are facing to the location of the hinges.
3. Install the parallel arm bracket on to the frame using the mounting screws.
4. Remove the screw and flat washer from the rocking arm and bolt. Disconnect the forearm from the arm shoe by removing the screw bolt and cylindrical nut connecting it with the forearm. Discard arm shoe. Connect the end of the forearm on to the shaft of the parallel arm bracket and secure with screw bolt.
5. Install rocker arm on top of pinion nut with the screw provided. Preload the closer by rotating the arm 45° towards the hinge side of the door.
6. Adjust the length of the adjustable forearm so that it is perpendicular to the door when assembled to preloaded rocker arm. Secure forearm to rocker arm by tightening the nut.
7. Snap dustproof cap cover over pinion nut.

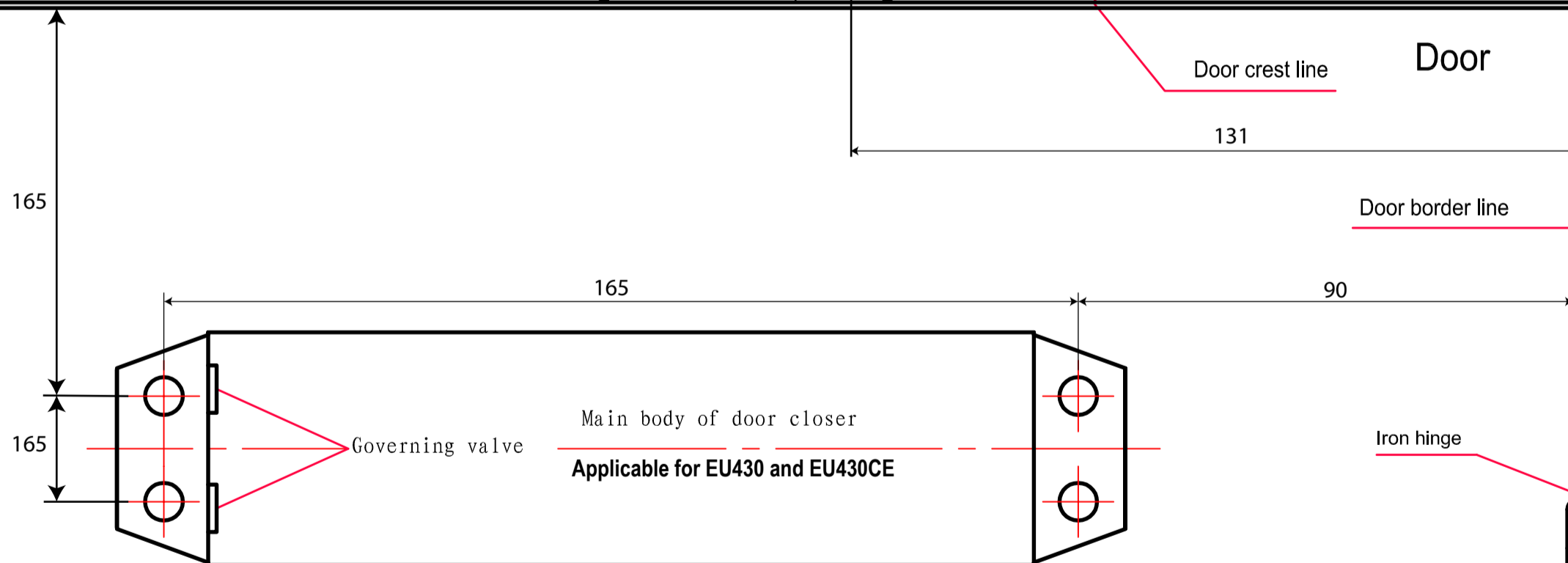

SPEED ADJUSTMENT

1. "I" is the SWEEP governing valve. "II" is the LATCH governing valve. Turning the governing valve counter clockwise speeds up action, turning it clockwise decelerates speed.

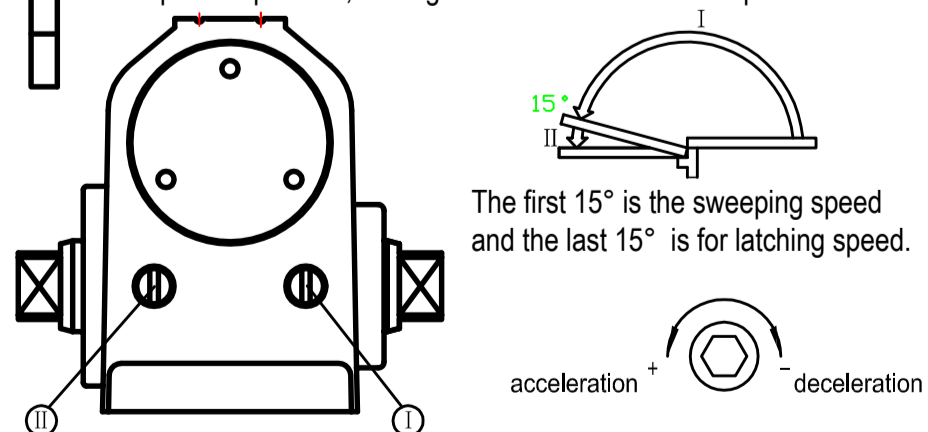

- ①. Screw and flat washer
- ②. Rocker-arm
- ③. Nut
- ④. Governing valve
- ⑤. Bolt
- ⑥. Parallel plate
- ⑦. Main body of door closer
- ⑧. Dustproof cap
- ⑨. Assembling screw
- ⑩. Assembling screw

TOP VIEW PARALLEL ARM INSTALLATION

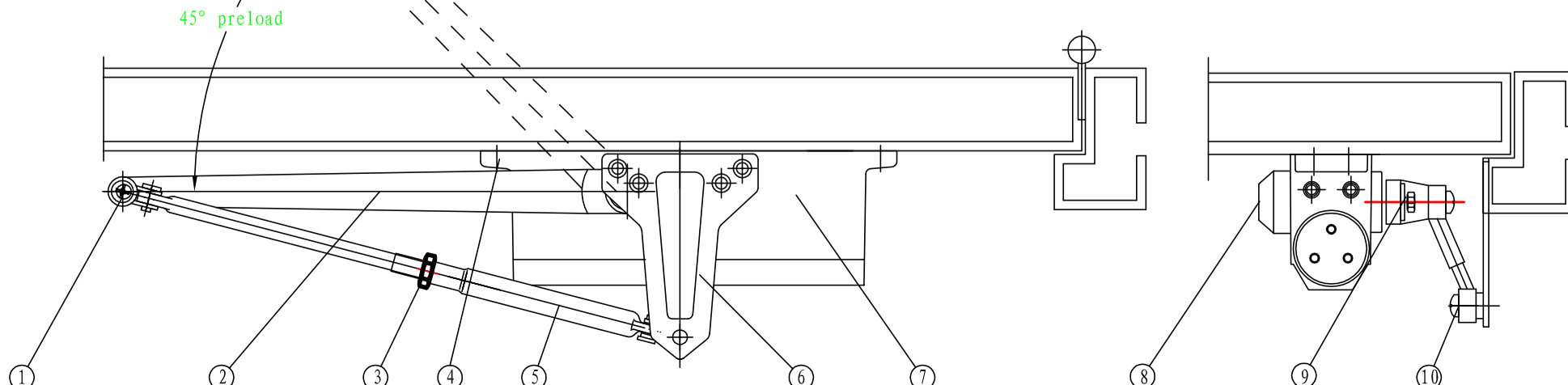

NOTE

1. The door closer has automatic closing function, DO NOT close door forcibly.
2. Retighten each screw after first 15 days. Make sure assembling screw of rocker arm is tight.
3. Weather conditions have an effect on the closing speed, re-adjust closing speeds during the start and end of each season.