

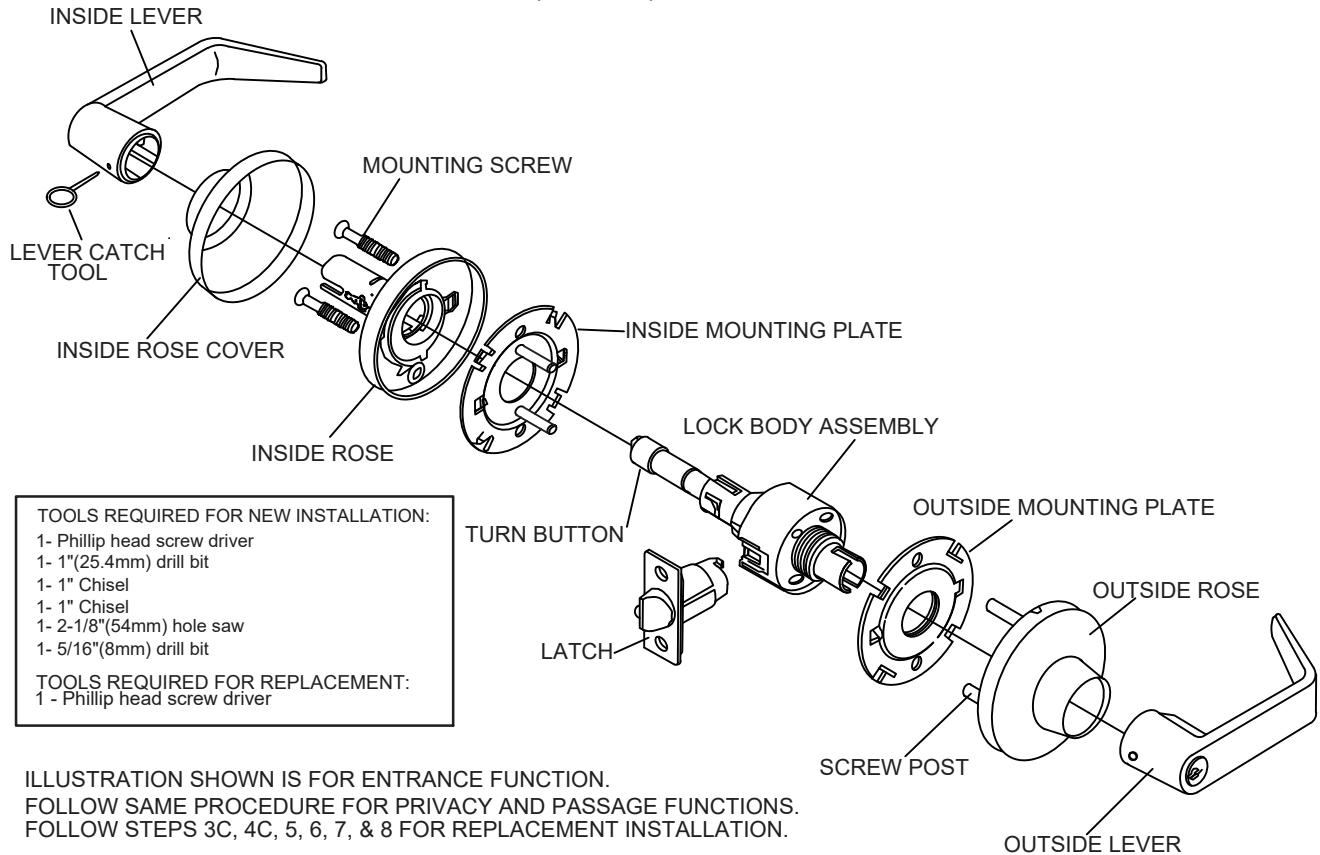

CALYPSO, CAL SERIES
INSTALLATION INSTRUCTIONS
COMMERCIAL KEY-IN LEVER
 FOR USE ON DOOR 1-3/8 ~ 2" (35~51mm) THICK



- TOOLS REQUIRED FOR NEW INSTALLATION:**
- 1- Phillip head screw driver
 - 1- 1"(25.4mm) drill bit
 - 1- 1" Chisel
 - 1- 1" Chisel
 - 1- 2-1/8"(54mm) hole saw
 - 1- 5/16"(8mm) drill bit
- TOOLS REQUIRED FOR REPLACEMENT:**
- 1 - Phillip head screw driver

ILLUSTRATION SHOWN IS FOR ENTRANCE FUNCTION.
 FOLLOW SAME PROCEDURE FOR PRIVACY AND PASSAGE FUNCTIONS.
 FOLLOW STEPS 3C, 4C, 5, 6, 7, & 8 FOR REPLACEMENT INSTALLATION.

1. MARK DOOR

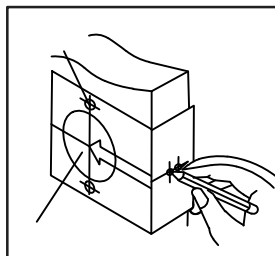

- A. Start 38" from floor and mark center of door edge.
- B. Select backset (2-3/8" or 2-3/4") and mark hole center on door face
- NOTE:
 BACKSET ON DOOR FACE MUST BE SAME AS BACKSET OF YOUR LOCK.
- C. Mark two holes for screw post.

2. DRILL HOLES

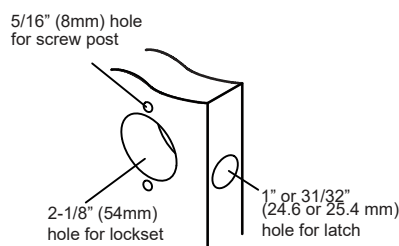

Drill holes as marked

NOTE:
 Drill 2-18" (54mm) hole from both sides to avoid splitting wood.

3. INSTALL LATCH

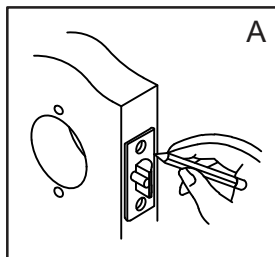

- A. Insert latch in hole and keep it parallel to door face. Mark outline and remove latch.
- B. Chisel 11/64" (4~4.3mm) deep or until faceplate flush with door edge.
- C. Insert latch and tighten screws
- NOTE: LATCHBOLT BEVEL MUST FACE TO CLOSING DIRECTION.

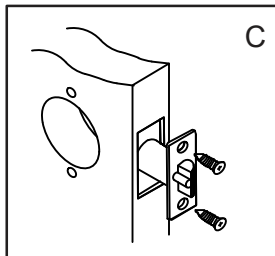
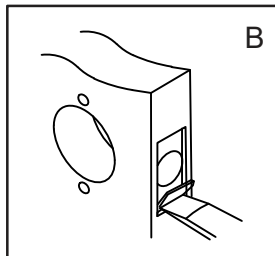

4. INSTALL STRIKE

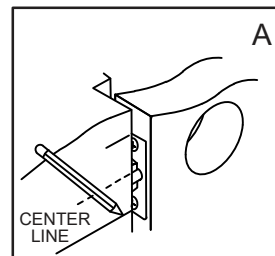

- A. Close door to mark horizontal line of strike
- B. Measure one half of door thickness from door stop to mark vertical center line of strike. Drill 1" (25.4mm) hole, 1/2" (12.7mm) deep at intersection of horizontal and vertical center lines.
- C. Cut out jamb 3/32" (2.4mm) deep or until strike flush with jamb. Tighten screws securely.

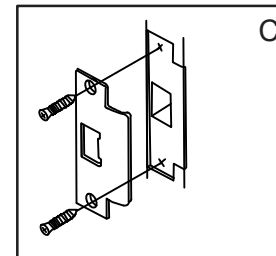
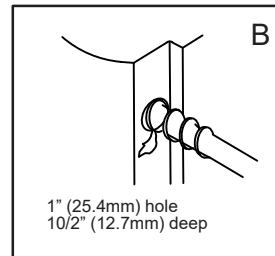



5. REMOVE INSIDE TRIM

Use lever catch tool to depress lever catch visible under hole of inside lever shank and slide off inside lever, rose and mounting plate.

ADJUST DOOR THICKNESS

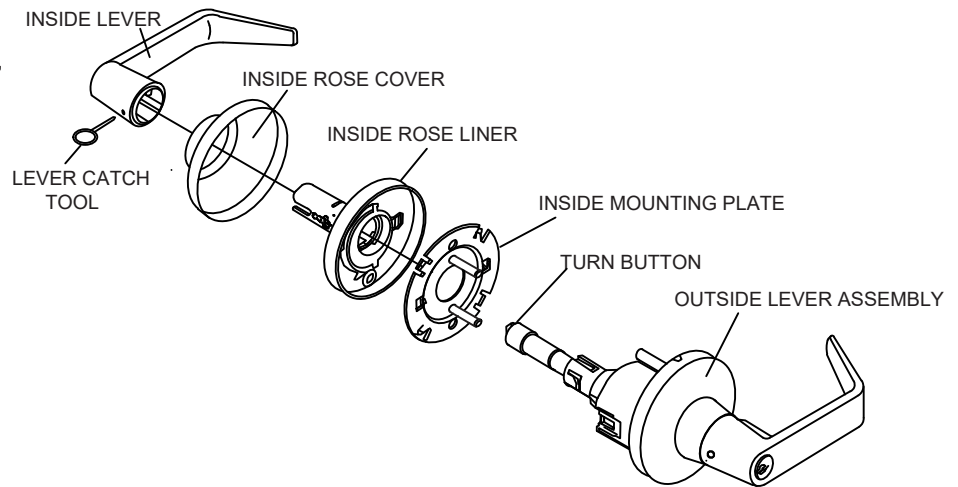
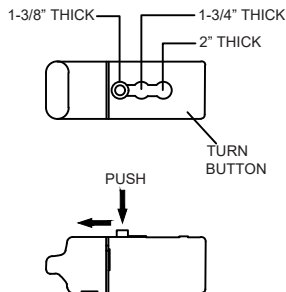

6. ADJUST DOOR THICKNESS

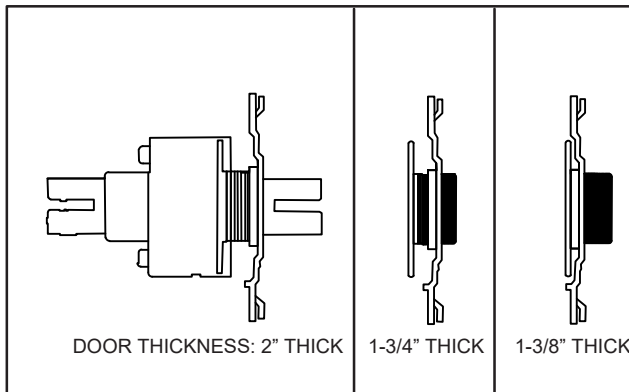

7. INSTALL OUTSIDE LEVER ASSEMBLY

Install outside lever assembly on the door. Make sure tail of latch is engaging with retractor correctly as illustrated.

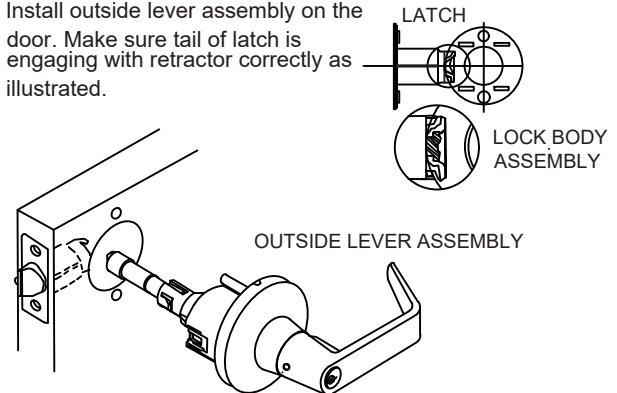

8. INSTALL INSIDE MOUNTING PLATE AND ROSE LINER

A. Install inside mounting plate to lock body.

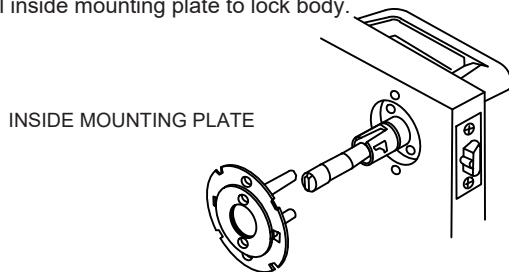

B. Press inside rose liner onto mounting plate and tighten mounting screws securely.

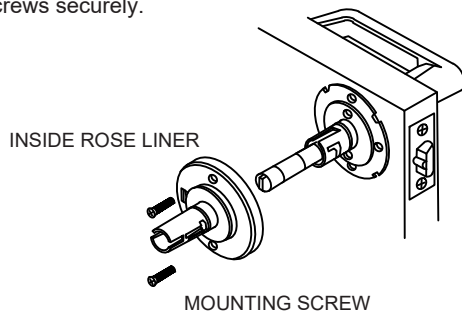

9. INSTALL INSIDE ROSE AND LEVER

A. Make sure to fit rose in recess of rose liner

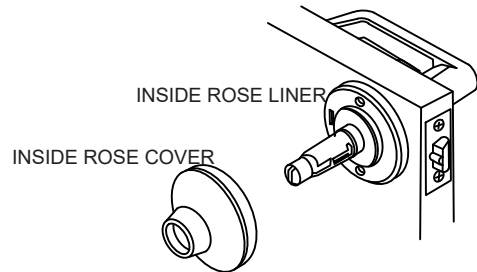

B. Depress lever catch with tool provided. Push inside lever on completely until catch engages in lever. Check if lever is secured.

