

CRP / DKS LOUVERS

TYPE: VLV Louvers

INSTALLATION INSTRUCTIONS:

1. Prior to installation read and follow all door manufacturer's instructions and requirements for application of the louver kit. Instruction may vary between different types and size application.
2. Cut receiving hole in the door corresponding to the order size of the louver. Make certain the cut out is square in the door.
3. Insert the corridor side (outside) of the louver into the opening. Use shim material if necessary to square the unit.
4. Insert the inside louver side into the cut out. Align pre-drilled holes then tighten using the screw provided.
5. Tighten the screws in cross pattern to obtain even pressure on the frames, while making the louver square and aligned to the door. Do not over tighten the screw.

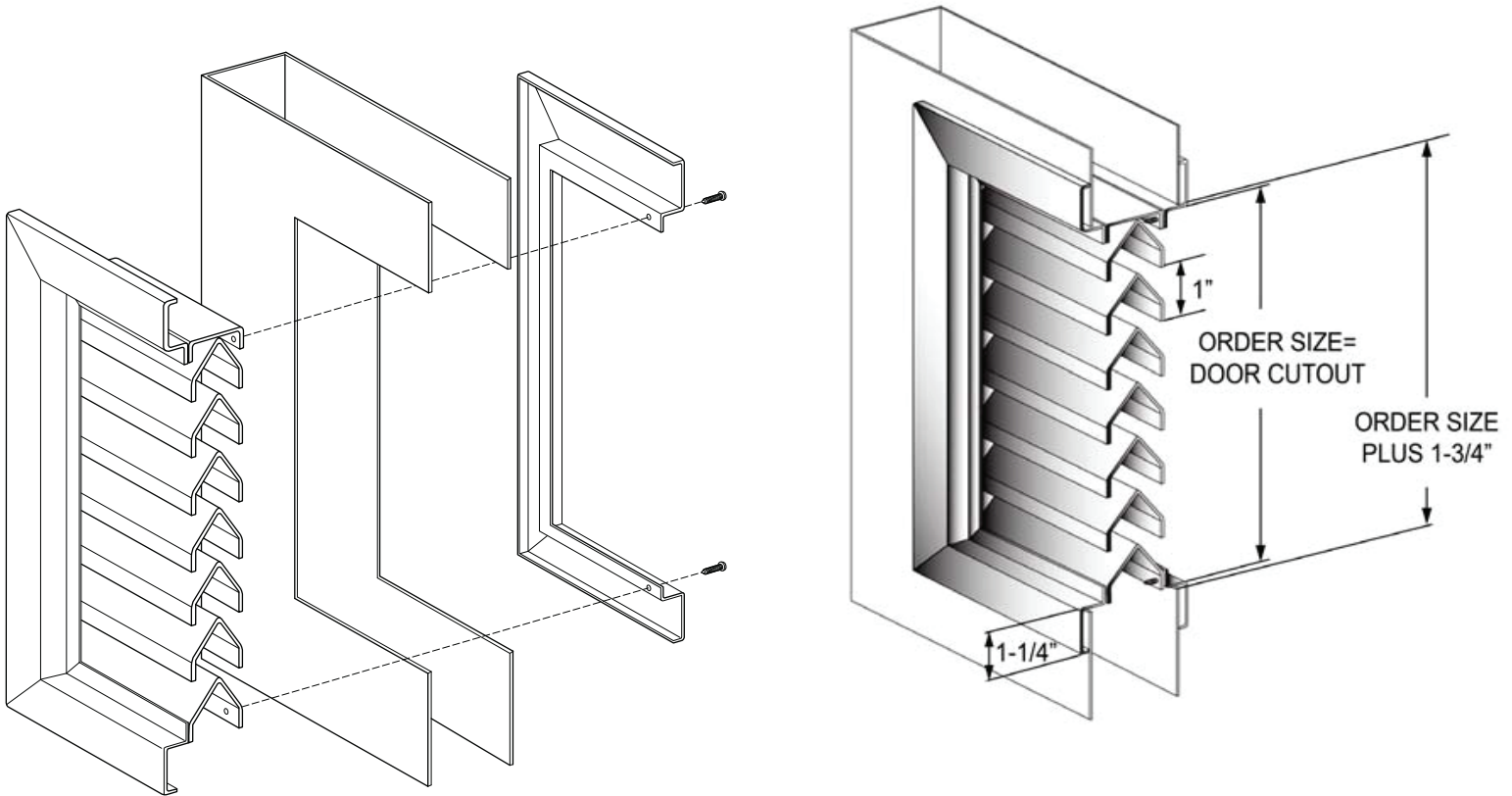

Cal-Royal Products, Inc.
6605 Flotilla St.
Commerce, CA 90040 U.S.A.
Phone: (323) 888-6601 ♦ (800) 876-9258
Fax: (323) 888-6699 ♦ (800) 222-3316
Email: sales@cal-royal.com
Website: www.cal-royal.com



DKS Steel Door & Frame Systems, Inc.
2142 Tubeway Ave.
Commerce, CA 90040 U.S.A.
Phone: (323) 888-7763
Fax: (323) 888-0063
Email: dks@cal-royal.com
Website: www.dksdoors.com