

# INSTALLATION INSTRUCTION FOR CAL-ROYAL N-FMR9800 SERIES MORTISE EXIT DEVICE

## BEFORE INSTALLING DEVICE, PLEASE CHECK :

1. IF DOOR FITTED AND HUNG.
2. SIZE OF EXIT DEVICE, FUNCTION AND DESIGN...
  - 2.1. 36" DOORS, CAN BE CUT TO FIT DOORS DOWN TO 30" WIDE.
  - 2.2. 48" DOORS, CAN BE CUT TO FIT DOORS DOWN TO 36" WIDE.
  - 2.3. HAND OF DEVICE AGAINST APPLICATION.

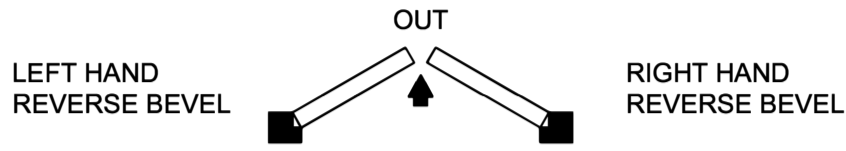

SURFACE OF DOOR FOR EXIT DEVICE APPLIED MUST BE FLUSHED.

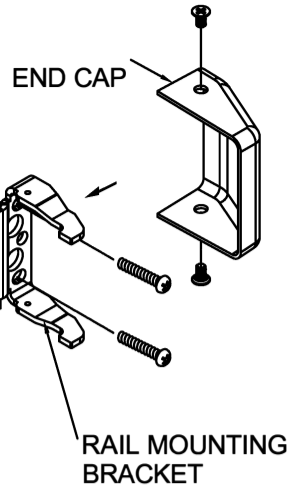

MOUNTING RAIL

PUSH RAIL

CHASSIS ASSEMBLY

HEAD COVER

LIFT ARM

HORIZONTAL  $\varnothing$  CHASSIS

VERTICAL  $\varnothing$  CHASSIS

(LHRB)

## 3. APPLY EXTERIOR TRIMS

If ESC lever trim is used, attach outside trim and cylinder.

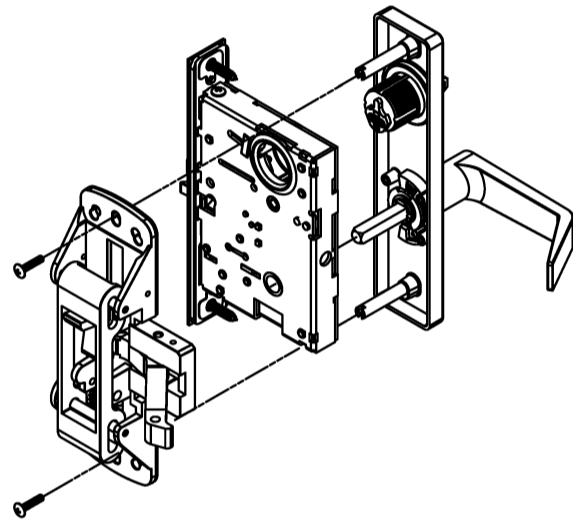

## 4. APPLY RAIL ASSEMBLY

1. CHECK THE SIZE OF DEVICE, IF CUTTING TO LENGTH IS REQUIRED.
2. DETERMINE CUT OFF LENGTH "X" BY SUBTRACTING 1-3/4" (44.5mm) FROM "Y". MARK CUT OFF POINT ON MOUNTING RAIL.

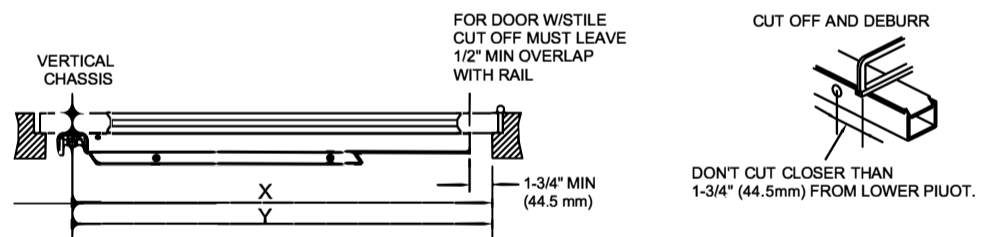

3. DEPRESS ARM INTO RAIL OPENING AND SLIDE RAIL ONTO CHASSIS. LEVEL RAIL AND FASTEN CHASSIS AND MOUNTING PLATE.

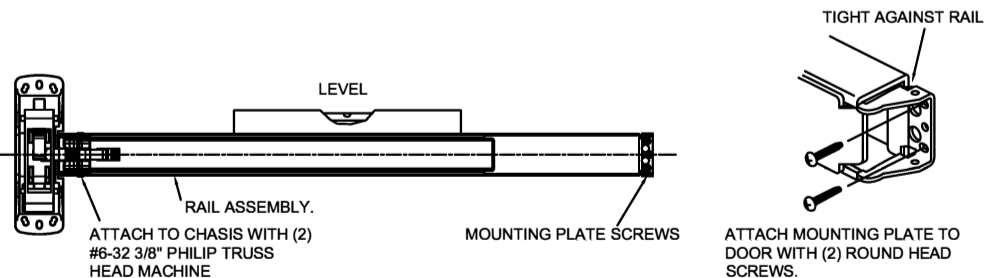

## 5. APPLY COVER AND STRIKES

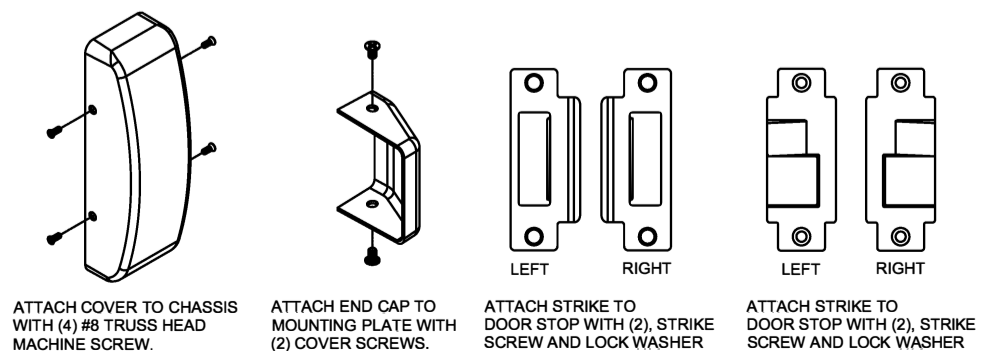

## 1. PREPARE DOOR AND MOUNT LOCK

Tape templates to inside face and edge of doors according to directions given on template. Drill holes and mortise door for lock as indicated.

Fasten mortise lock in plate

NOTE: If screwless rose trim is used -- refer to trim instructions and mount lock in conjunction with rose and inner plates

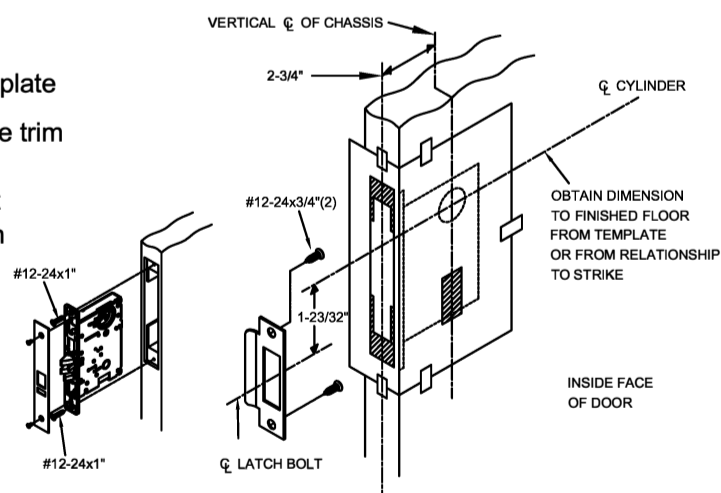

## 2. ATTACH CHASSIS TO DOOR

2.1 Attach chassis to Rail, then lock push rail down, using

2.2 Position chassis and rail on door, so that lever arm is under rear section of Mortise lock lever. Then lift up until latchbolt is completely retracted.

2.3 With chassis in this position and rail horizontal, mark location of chassis mounting holes. Drill holes for screws.

2.4 Release Push rail, and dis-ass'y chassis from rail.

Then, mount chasis on door.

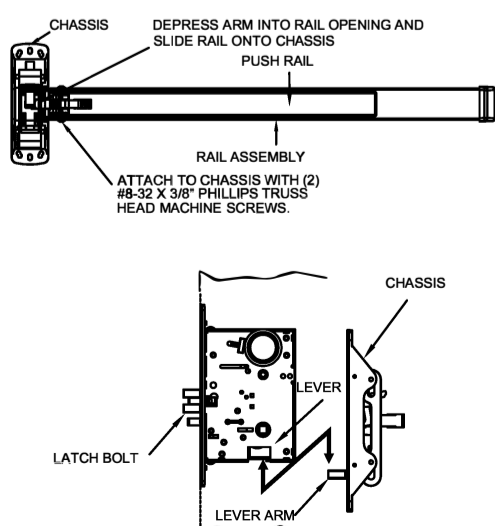

# TO CHANGE HAND OF N-FMR98 EXIT DEVICE

1. LHR

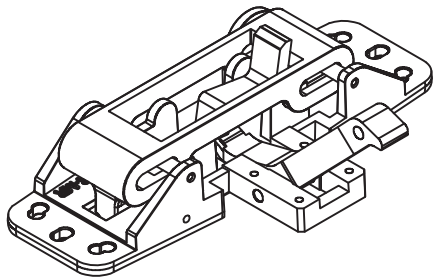

- 2-1. Remove chassis pin & main slide & tube.
- 2-2. Remove lift lever & lift lever pin.
- 2-3. Rotate 180° main slide & lift lever

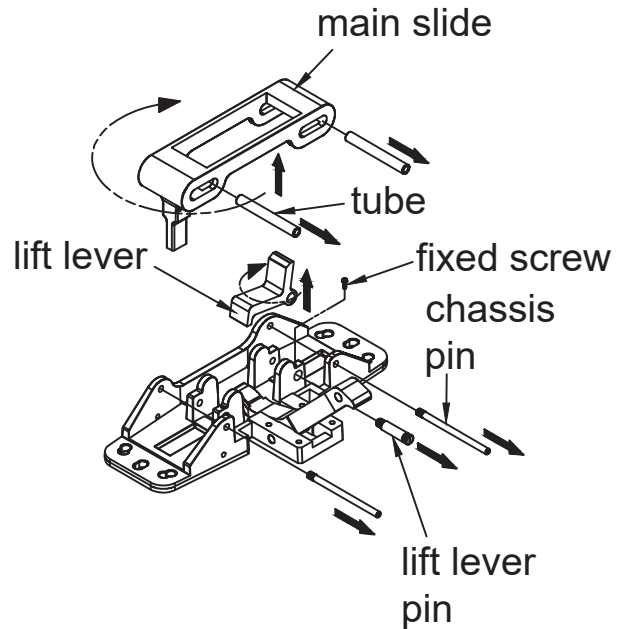

- 3-1. Reassemble lift lever at opposite side, as shown.
- 3-2. Replace main slide and chassis pin and lift lever pin and fixed screw.

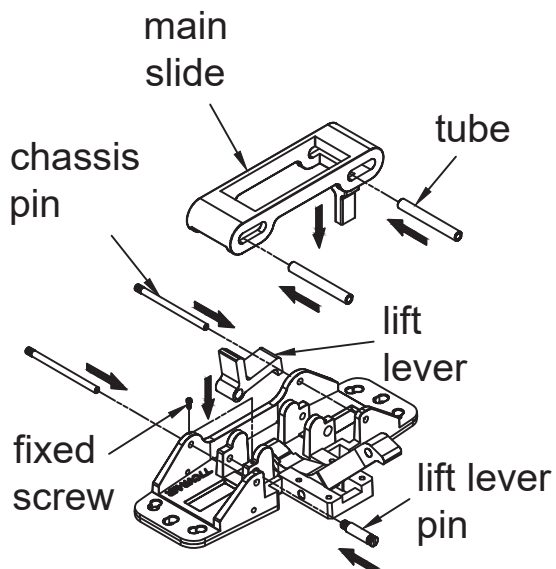

1. RHR Done.

