

# ESC7700 / ESC7705 / ESC7730 / ESC7740 Exit Trim

- FOR WOOD DOOR-DRILL (4) 3/32" DIA. X 1-1/4" DEEP (WOOD SCREW PILOT HOLES).
- FOR META DOOR-DRILL & TAP (4) 3/16"-24 HOLES.
- FOR THRU BOLTING DRILL (4) 13/32" DIA. HOLES THRU DOOR

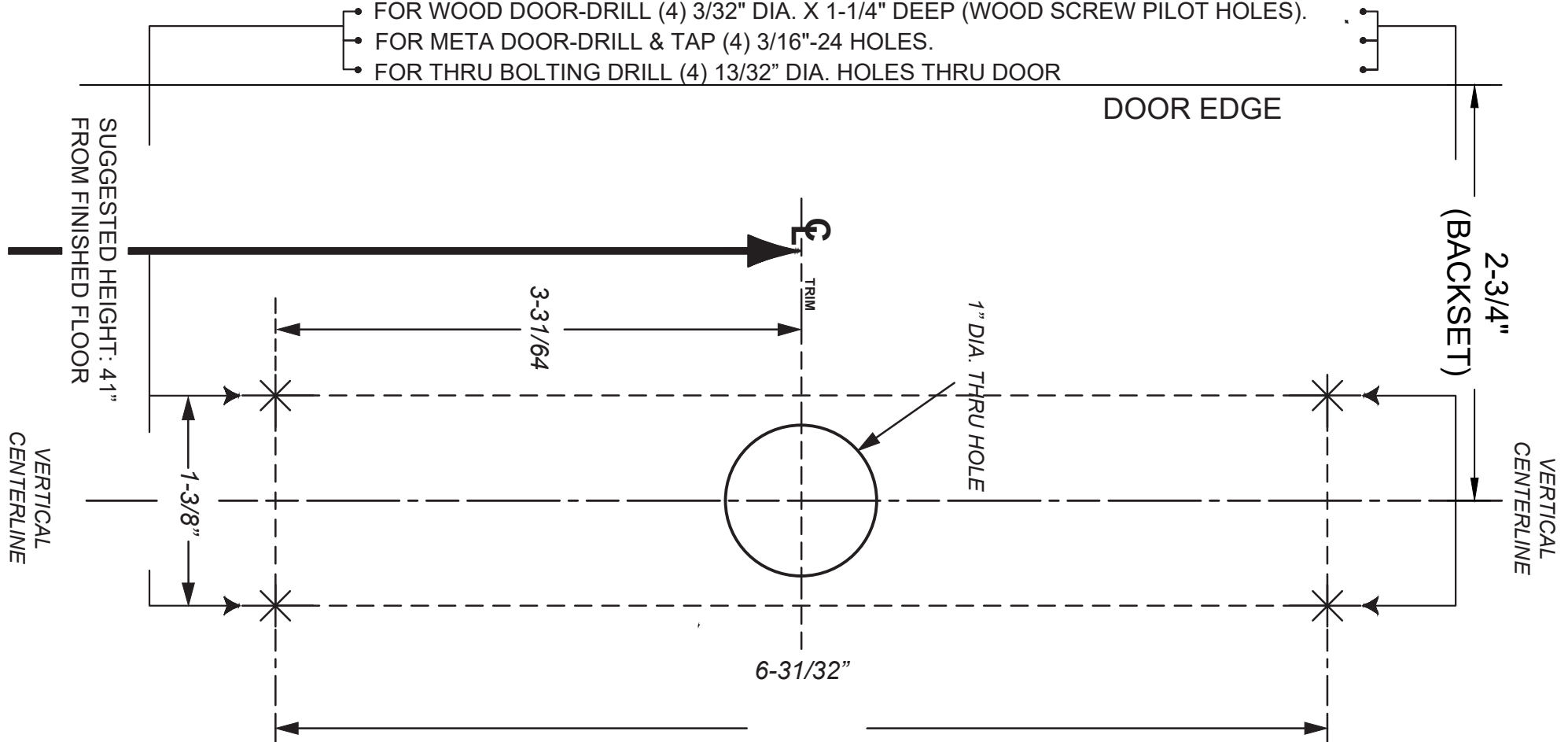

**NOTE:**  
IF DOOR IS PREPPED FOR 2-1/8" HOLE,  
ESCUTHEON PLATE WILL COVER HOLE.

CONVERSION		
FRACTION (inches)	DECIMAL (inches)	MILLIMETER (mm)
6-31/32"	6.484	164.69
1-3/8"	1.375	34.93
3-31/64"	3.484	88.49
3/32"	0.094	2.39
1-1/4"	1.25	31.75
3/16"	0.1875	4.76
13/32"	0.4063	10.32

The illustration and technical description in this cut sheet is current as of the date in version date on the right. Cal-Royal Product reserves the right to, and may, on occasions, make changes and/or improvements in designs and dimensions without prior notice.



6605 Flotilla Street  
City of Commerce  
CA 90040 USA  
Tel:# (323) 888-6601  
FAX: # (323) 888-6699  
WEB SITE:  
CAL-ROYAL.COM  
Email: sales@cal-royal.com

ITEM NO.	DESCRIPTION :
ESC7700	TEMPLATE FOR ESC7700

NOT TO SCALE  
PAGE 1 OF 1

UNIT  
PRIMARY DIMENSION SHOWN IN INCHES, DIMENSIONS IN ( ) ARE MM

Prepared By: BBT / ADG / CVL

DATE  
mm/dd/yr

DRWG. NO.  
EDT-4152-09/24-1 of 1  
REV