

DRILL 1"(25mm) HOLE
AT CENTER OF
DOOR EDGE

FOLD ON DOOR EDGE
FOLD ON DOOR EDGE

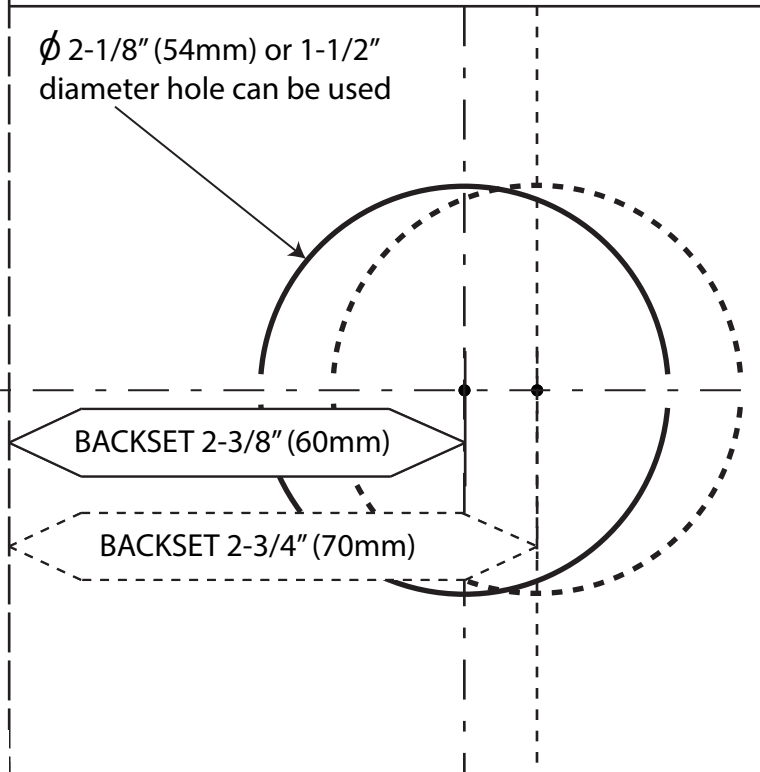
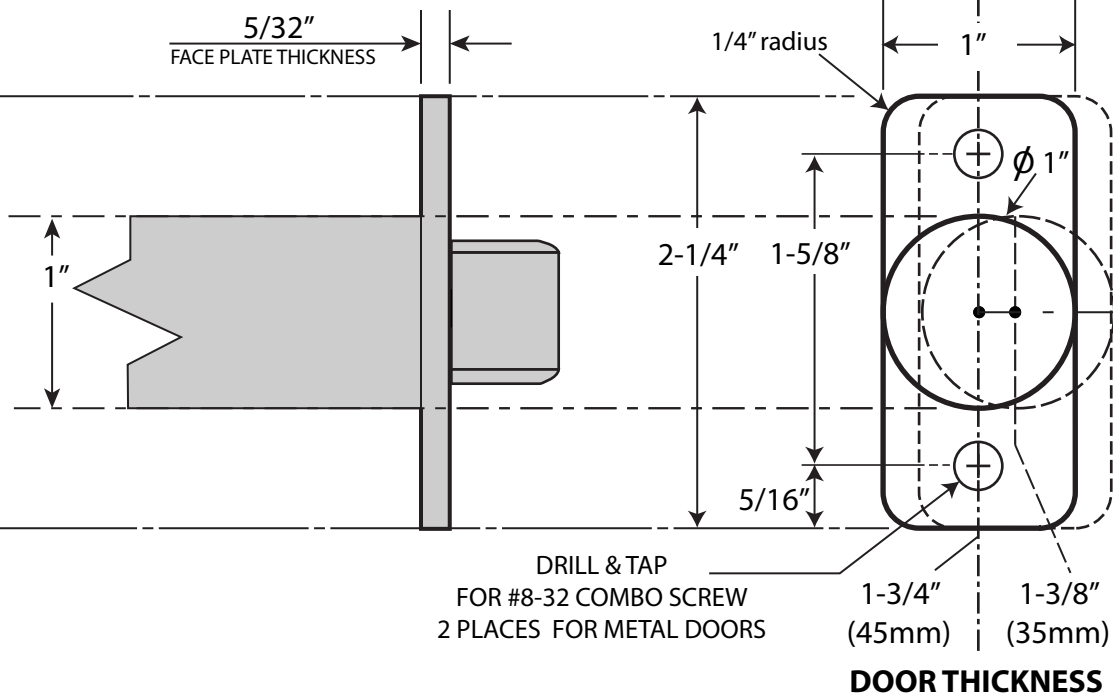

1. MARK DOOR

- Fold and apply to high edge of door bevel and mark center of door edge as indicated on template at the desired height from the floor.
- Mark center hole on door face through guide on template for 2-3/8" (60mm) or 2-3/4" (70mm) backset.

2. DRILL HOLES

- Drill thru door face as marked for lockset. It is recommended that holes be drilled from both sides to prevent splitting. Hole size is 2-1/8" (54mm) for standard installations.
 - Drill 1" (25mm) hole in center of door edge thru 2-1/8" (54mm) hole for latch.
- CAUTION: Check center of latch hole for alignment with strike center on jamb to ensure free movement of latch bolt.



6605 Flotilla St.
City of Commerce
CA 90040 USA
Tel: (323) 888-6601
FAX: (323) 888-6699
Website: cal-royal.com
Email: sales@cal-royal.com

ITEM NO.

RITZ - 20

DESCRIPTION

**ASHLEY SERIES
RESIDENTIAL LOCKSET**
FUNCTION: PRIVACY

ANSI

Grade 3

SCALE

1 : 1

PAGE 1 OF 1

UNIT

inches
(mm)

VERSION

ver. 1.0 rev. 01/12

BY: bteves/adg